

**R410A GAS**  
**HWA1 range of air-cooled chillers  
and reversible heat pumps**

106kW-349kW

40kW-85kW



# HWA1-A 0140-0285

# HWA1-A/H 0140-0285 \*

## Water chiller and heat pump reversible air/water

40 kW-85 kW



(\*) Eurovent certified product range

The water chillers and air/water heat pumps have been designed for commercial and industrial applications; they are very compact yet equipped with large-surface air-side heat exchangers, ensuring high efficiency with EER and COP among the highest in their category.

The use of high-efficiency, particularly robust scroll compressors together with the oil recovery and distribution system used on tandem circuits ensures high reliability and consistent performance.

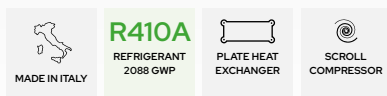

**Carpentry:** all units in the series are manufactured from hot-dip galvanized sheet metal and painted with polyurethane powder coatings baked at 180°C to ensure maximum resistance to atmospheric agents.

**Refrigerant circuit:** made using components from leading international manufacturers and in compliance with UNI EN 13134. The refrigerant used is R410A. The refrigerant circuit in its basic version includes: electronic expansion valve, liquid separator, liquid receiver, service valves for maintenance and control, safety device compliant with the PED directive (high-pressure switch), safety valve for the refrigerant, pressure transducers to accurately measure evaporation and condensation pressures, high-capacity drier filter to prevent throttling valve blockages and eliminate any moisture present in the circuit, and liquid sight glass for checking the refrigerant charge. In heat pump versions, a 4-way cycle-reversing valve and an outdoor air temperature sensor are also provided.

**Compressors:** scroll type, specifically designed to operate with R410A, mounted on rubber anti-vibration mounts. The crankcase heater, where present, is activated when the compressor is stopped and is disabled when the compressor restarts.

**Air-side heat exchangers:** for chillers it is made entirely of aluminum using the new microchannel technology, which makes it possible to reduce significantly both the air-side pressure drops and the refrigerant charge, while at the same time ensuring a higher heat exchange capacity for the same frontal surface compared with traditional heat exchangers. In the

heat pump versions, the heat exchanger is a finned coil with fin spacing optimized for operation at low temperatures.

**Fan:** axial type with airfoil-profile blades. Supplied complete with protective grille and inlet/outlet nozzles with double flared profile, specially shaped to increase efficiency and reduce noise.

**User-side heat exchangers:** brazed-plate type, made of AISI 316 stainless steel and factory-insulated with closed-cell material; they can be equipped with an electric antifreeze heater. Each evaporator is protected by a temperature probe used as an antifreeze protection sensor that activates the circulator (if present), even when the unit is switched off, if the conditions set on the controller occur.

**Control system:** all units are equipped with a microprocessor-based control board with superheat control logic managed according to the signals sent by the pressure transducers and temperature probes. The CPU also controls the following functions: water temperature regulation, antifreeze protection, compressor timing and start-up, management of fan and circulation pumps (if present), alarm reset, alarm indication and operating status LEDs. On request, the microprocessor can be connected to remote BMS control systems. With the addition of the expansion module, it is possible to control an external 3-way valve, either modulating or 2-position, via the controller.

## Operating Areas

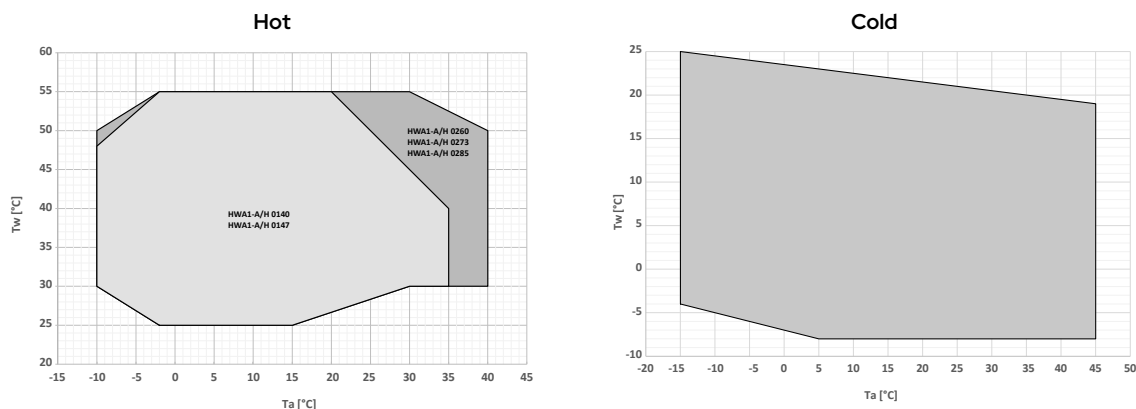

Tw: water temperature - Ta: outdoor air temperature

## Accessories

### Factory-installed

- **KA** - Anti-freeze heater on: heat exchanger and base. Electric heater installed on the front side of the plate heat exchanger, which is activated when the water temperature inside the exchanger falls below +4°C. A heating cable is installed on the base to melt any ice that may form. (HWA1-A/H).
- **KA1** - Anti-freeze heater on heat exchanger. Electric heater installed on the front face of the plate heat exchanger, which is activated when the water temperature inside the exchanger falls below +4°C. (HWA1-A).
- **DSFR** - Three-phase relay for overvoltage and undervoltage monitoring + phase loss/sequence. Indicates the presence of all three phases in the correct sequence and whether all three line-to-line voltages are within the set limits. It is possible to set the overvoltage and undervoltage thresholds separately.
- **SL \*\*** - Silenced version. The silenced unit (equipped with the SL accessory) features an innovative thermo-acoustic jacket on the compressors. This insulation allows a noise reduction of up to 10% at certain compressor rotation frequencies. The special multi-layer structure provides thermal insulation that, at low temperatures, reduces losses by up to 2% compared to standard insulation.
- **SSL \*\*** - Super silenced version. The super silenced unit (equipped with the SSL accessory) includes, in addition to the thermo-acoustic jacket on the compressors, a special fan with diffuser. This component increases the fan efficiency, allowing its speed to be reduced, thereby lowering sound pressure and energy consumption. In this way it is possible to save significant amounts of electrical energy for each fan.
- **C\*\*** - Ductable version. With the ductable version, the diffuser is used to take advantage of the higher available pressure of the fan and, if required, to duct the air discharge.
- **C(S)\*\*** - Ductable version with jackets. In addition to the ductable version, thermo-acoustic jackets are installed on the compressors.
- **EC** - Modulating EC fan (standard for size O285 cooling only, size O273–O285 heat pump). Includes the CC function, condensation control down to -15°C. Mandatory accessory for cooling-only versions, comfort applications, EU market.
- **PS** - Fixed-speed AC circulation pump.
- **CM** - BMS connectivity setup – ModBus protocol included – accessory that enables the connection of the unit to external controllers via serial cable with RS-485 electrical standard and ModBus RTU protocol.
- **GI** - Hardware expansion module. Additional expansion board installed at the factory that increases the resources (I/O) available in the system.
- **TR1** - Microchannel coil with Aero surface treatment. The treatment consists of spraying a special water-based coating made of new resins with very high chemical resistance. The product is flexible to withstand thermal contractions and expansions, UV-resistant, dirt-repellent, mechanically resistant, with very limited heat transfer losses and practically no effect on air-side pressure drops. The treatment withstands 6000 h according to ASTM B117. (HWA1-A).
- **TR2** - Coil anti-corrosion treatment – thanks to this treatment, the coil becomes flexible to withstand thermal contractions and expansions, mechanically resistant, UV-protected and dirt-repellent. Heat transfer losses are very limited. The treatment ensures coil protection under virtually all environmental conditions: from coastal to rural areas, from industrial to urban zones. The treatment withstands 6,000 hours according to ASTM B117. (HWA1-A/H).
- **IM** - Circuit breakers on compressors and fans – overcurrent switches applied to compressors and fans, protecting the components from faults caused by possible current spikes.

### Provided separately

- **SAS** - Remote system probe. The remote system probe controls the heat pump temperature only during the compressor start-up phase; shutdown is managed by the probe installed on the heat pump flow line.
- **AG** - Rubber anti-vibration kit – designed to prevent vibration transmission to the structure; they are to be installed beneath the unit, in the designated mounting holes.
- **FY** - Y-strainer – contains a stainless steel mesh screen (500 µm filtration) that collects solid materials present in the water. Filtration prevents blockage and/or damage to the devices installed downstream of the strainer. Alternatively, it is possible to install a dirt separator that ensures a filtration level not greater than 1 mm (in this case, it is no longer necessary to install the Y-strainer).
- **i-CR2\*\*** - Wall-mounted remote control – Modbus remote controller with negative LCD and capacitive keys. The device is intended to be used as a remote unit keypad with local temperature sensing and replicates the functions of the on-board unit controller.
- **Hi-TV415\*\*** - Color touch screen wired remote controller for the centralized management of a cascade of chillers/heat pumps, for up to 7 units.



**i-CR2**  
Wall-mounted  
remote control  
**ACCESSORY**



**Hi-TV415**  
Touch screen remote  
controller for cascade  
management (max 7 units)  
**ACCESSORY**

HWA1-A			0140	0147	0260	0273	0285
Cooling	Cooling capacity (1)	kW	39,7	46,8	60,8	73,3	86,5
	Power input (1)	kW	12,5	15,1	19,3	24,8	29,3
	EER (1)	W/W	3,16	3,11	3,16	2,95	2,96
	Cooling capacity (2)	kW	54,4	63,5	81,9	99,4	116,3
	Power input (2)	kW	14,3	17,0	21,9	28,0	33,3
	EER. (2)	W/W	3,80	3,74	3,75	3,55	3,50
	SEER (5)	W/W	3,80	3,80	4,05	3,98	4,14
	Cooling capacity (8)	kW	22,7	27,0	36,2	42,9	51,1
	Total absorbed power (8)	kW	11,4	13,5	16,9	22,1	25,7
	EER (8)	W/W	1,99	2,01	2,14	1,94	1,99
Water flow rate (1)	l/s	1,90	2,24	2,91	3,51	4,14	
Pressure drops in the heat exchanger on the user side (1)	kPa	54,08	51,68	56,79	46,43	50,41	
Compressor	Type		Scroll				
	Number		1	1	2	2	2
	Standard capacity steps		1	1	2	3	3
	Refrigerant circuits		1	1	1	1	1
	Oil (type, quantity)	dm <sup>3</sup>	BVC32 / 2,7		BVC32 / 5,4		
Refrigerant	Type		R410A				
	Refrigerant quantity (4)	kg	7,8	7,8	12,8	13,4	14,6
	Tons of CO <sub>2</sub> equivalent (4)	Ton	16,3	16,3	26,7	28	30,5
	Refrigerant quantity BT model (4)	kg	8,5	8,5	12,8	13,4	14,6
	Tons of CO <sub>2</sub> equivalent BT version (4)	Ton	17,8	17,8	26,7	28	30,5
Design pressure (high/low)	MPa	4,2/2,7					
Outdoor zone fans	Type		AXIAL				
	Number		1				
	Maximum power	kW	1,90	1,90	1,90	1,85	3,2
	Absorbed current (max)	A	3,9	3,9	3,9	3,8	4,65
	Nominal air flow rate	m <sup>3</sup> /s	4,04 / 5,32	3,88 / 5,23	4,15 / 5,44	4,86 / 6,01	7,4
	ΔP available for DUCTED VERSION	Pa	50	50	39	40	39
Internal heat exchanger	Internal heat exchanger type		PLATE-TYPE				
	No. of indoor heat exchangers		1	1	1	1	1
	Water content	l	2,03	2,46	3,21	4,64	5,25
Hydronic circuit	Maximum pressure of the hydronic kit	bar	6				
	Hydraulic connections	inch	2"				
	Minimum system water volume (5)	L	330	380	260	380	490
Sound data	Sound power (6)	dB(A)	81	81	82	83	84
	Sound pressure (7)	dB(A)	49,3	49,3	50,3	51,3	52,3
Electrical data (version without accessories)	Power supply		400V/3P+N+T/50Hz				
	Maximum absorbed power	kW	17,4	19,8	26,5	32,5	N.A.
	Maximum absorbed current	A	29,6	34,1	46,5	55,3	N.A.
	Maximum inrush current	A	156	183	155,3	204,3	N.A.
Electrical data with EC fan (version without accessories)	Power supply		400V/3P+N+T/50Hz				
	Maximum absorbed power	kW	17,45	19,85	26,55	33,4	39,5
	Maximum absorbed current	A	29	33,5	45,9	56,5	66,2
	Maximum inrush current	A	148,3	175,3	147,6	198,3	237,3

(1) Cooling: outdoor air temperature 35°C; inlet/outlet water temperature 12/7°C.

(2) Cooling: outdoor air temperature 35°C; inlet/outlet water temperature 23/18°C.

(3) Reference water temperature for internal heat exchanger = 12/7°C.

(4) Data is indicative and subject to change. For the correct value, always refer to the technical label on the unit.

(5) The calculated value of minimum system water volume does not take into account the water volume contained in the internal heat exchanger (evaporator). For applications with low outdoor air temperature or low required average loads, the minimum system water volume is obtained by doubling the indicated value.

(6) Condition (3); value determined on the basis of measurements carried out in accordance with UNI

EN ISO 9614-2, in compliance with the requirements of Eurovent certification.

(7) Value calculated from the sound power level using ISO 3744:2010, referenced to a distance of 10 m from the unit.

(8) Cooling BT version: outdoor air temperature 35°C, internal heat exchanger water temperature = -3/-8°C. Fluid treated with 35% ethylene glycol.

The performance data shown are indicative and may be subject to change. The capacities declared at points (1), (2), (8) are to be understood as referring to the instantaneous output in accordance with EN 14511. The data declared at point (3) are determined in accordance with UNI EN 14825.

HWA1-A/H			0140	0147	0260	0273	0285
Cooling	Cooling capacity (1)	kW	38,6	45,6	58,6	71,2	80,2
	Power input (1)	kW	13,0	15,7	19,9	24,6	29,2
	EER (1)	W/W	2,97	2,91	2,94	2,90	2,75
	Cooling capacity (2)	kW	51,8	60,6	77,7	94,1	106,4
	Power input (2)	kW	14,7	17,6	22,6	28,0	33,3
	EER. (2)	W/W	3,53	3,43	3,43	3,37	3,20
	SEER (5)	W/W	3,82	3,8	3,94	3,98	4,07
	Water flow rate (1)	l/s	1,86	2,20	2,83	3,41	3,84
Pressure drops in the heat exchanger on the user side (1)		kPa	55,8	56,6	61,5	63,7	66,6
Heating	Heating capacity (3)	kW	43,5	48,2	64,1	80,9	88,7
	Input power (3)	kW	10,7	12,3	15,6	20,0	22,7
	COP (3)	W/W	4,05	3,92	4,10	4,05	3,90
	Heating capacity (4)	kW	42,1	47,8	63,0	74,9	84,6
	Power input (4)	kW	12,8	14,8	18,8	23,3	28,5
	COP (4)	W/W	3,28	3,23	3,35	3,22	2,97
	SCOP (6)	W/W	3,49	3,34	3,85	3,84	3,70
	Water flow rate (4)	l/s	2,02	2,30	3,03	3,60	4,07
	Pressure drops in the heat exchanger on the user side (4)		kPa	84,4	81,6	84,1	81,5
Energy efficiency water 35°C		class	A+	A +	A++	A++	A+
Compressor	Type		Scroll				
	Number		1	1	2	2	2
	Standard capacity steps		1	1	2	3	3
	Refrigerant circuits		1	1	1	1	1
	Oil (type, quantity)	dm <sup>3</sup>	BVC32 / 2,7			BVC32 / 5,4	
Refrigerant	Type		R410A				
	Refrigerant quantity (7)		9,98	9,98	14	15,25	15,6
	Tons of CO2 equivalent (7)		20,8	20,8	29,2	31,8	32,6
	Design pressure (high/low)		4,2/2,7				
Outdoor zone fans	Type		AXIAL				
	Number		1	1	1	1	1
	Rated power (1)	kW	1,36	1,66	1,76	1,89	2,12
	Maximum power	kW	1,95	1,95	1,95	3,20	3,20
	Maximum absorbed current	A	3,30	3,30	3,30	5,00	5,00
	Nominal air flow rate	m <sup>3</sup> /s	4,3	5,3	6,3	6,9	7,4
ΔP available for DUCTED VERSION		Pa	41	44	35	33	35
Internal heat exchanger	Internal heat exchanger type		PLATE-TYPE				
	No. of indoor heat exchangers		1	1	1	1	1
	Water content	l	2,03	2,46	3,21	4,64	5,25
Hydraulic circuit	Maximum pressure of hydronic kit (safety valve setting)	bar	6				
	Hydraulic connections	inch	2"				
	Minimum system water volume (8)	L	330	380	260	380	490
Sound data	Sound power (9)	dB(A)	84	85	88	88	88
	Sound pressure (10)	dB(A)	52,3	53,3	56,3	56,3	56,3
Electrical data (version without accessories)	Power supply		400V/3P+N+T/50Hz				
	Maximum absorbed power	kW	17,4	19,8	26,5	N.A.	N.A.
	Maximum absorbed current	A	29,6	34,1	46,5	N.A.	N.A.
	Maximum inrush current	A	156	183	155,3	N.A.	N.A.
Electrical data with EC fan (version without accessories)	Power supply		400V/3P+N+T/50Hz				
	Maximum absorbed power	kW	17,45	19,85	26,55	33,4	39,5
	Maximum absorbed current	A	29	33,5	45,9	56,5	66,2
	Maximum inrush current	A	148,3	175,3	147,6	198,3	237,3

(1) Cooling: outdoor air temperature 35°C; inlet/outlet water temperature 12/7°C.

(2) Cooling: outdoor air temperature 35°C; inlet/outlet water temperature 23/18°C.

(3) Heating: outdoor air temperature 7°C d.b. 6°C w.b.; water inlet/outlet temp. 30/35°C.

(4) Heating: outdoor air temperature 7°C d.b. 6°C w.b.; water inlet/outlet temp. 40/45°C.

(5) Cooling: water inlet/outlet temperature 12/7°C

(6) Heating: average climatic conditions; T<sub>biv</sub> = -7°C; water temp. in/out 30/35°C

(7) Indicative data, subject to change. For the correct data, always refer to the technical nameplate on the unit.

(8) The calculated value of minimum system water volume does not take into account the water volume contained in the internal heat exchanger (evaporator). For applications with low outdoor air temperatures or low required average loads, the minimum system water volume is obtained by doubling the indicated value.

(9) Condition (3); value determined on the basis of measurements carried out in accordance with standard UNI EN ISO 9614-2, in compliance with the requirements of Eurovent certification.

(10) Value calculated from the sound power level using ISO 3744:2010, referred to a distance of 10 m from the unit.

N.B. The stated performance data are indicative and may be subject to change. The capacities declared in points (1), (2), (3) and (4) are to be understood as referring to the instantaneous power according to EN 14511. The data declared in points (5) and (6) are determined in accordance with UNI EN 14825.

Range of Eurovent-certified products



# Dimensional Drawings

HWA1-A & HWA1-A/H 0140 / 0147 / 0260 / 0273 / 0285

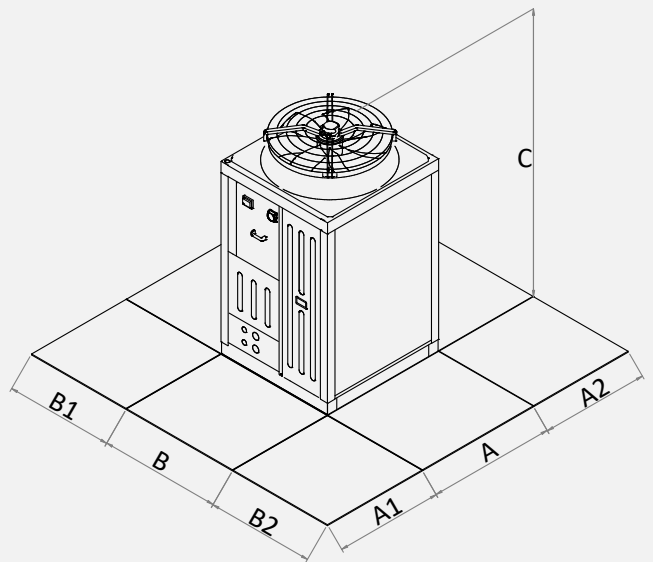
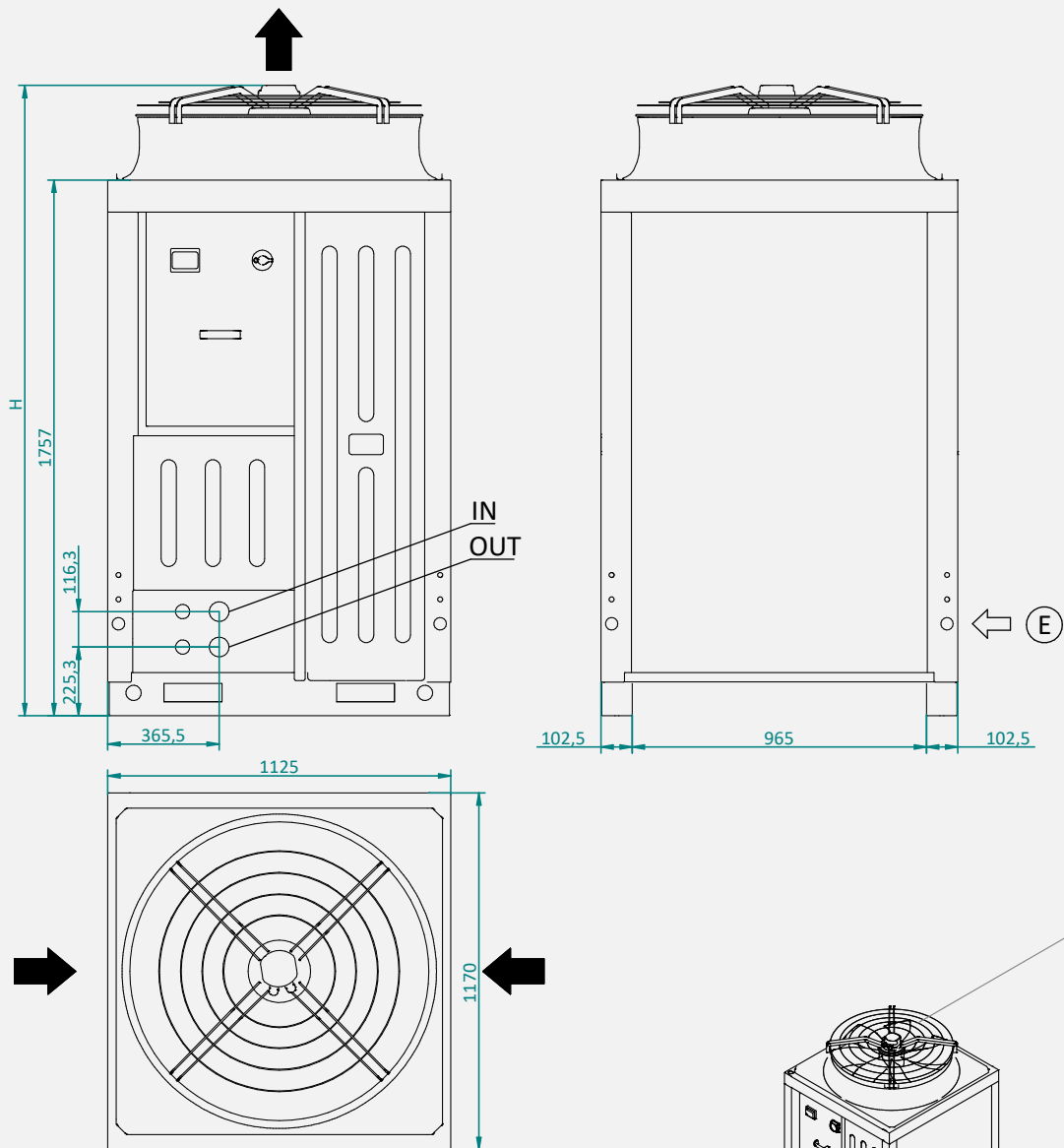

		0140	0147	0260	0273	0285
L	mm	1125	1125	1125	1125	1125
D	mm	1170	1170	1170	1170	1170
H	mm	2014	2014	2110	2110	2110
H (SSL)	mm	2200	2200	2220	2220	2220

Clearances		A1	A2	B1	B2
0140	mm	800	800	200	600
0147	mm	800	800	200	600
0260	mm	800	800	200	600
0273	mm	800	800	200	600
0285	mm	800	800	200	600

Dimensions in mm

## Price list

<b>HWA1-A</b>		<b>0140</b>	<b>0147</b>	<b>0260</b>	<b>0273</b>	<b>0285</b>
HWA1-A	Cooling only	£ 16.040	19.102	22.798	24.491	27.573
HWA1-A/BT	Cooling only for low-temperature chilled water production (including EC fan)	£ 18.964	21.966	25.663	27.358	30.439
<b>FACTORY-MOUNTED ACCESSORY MANDATORY: Standard EC fan for ERP regulation to be added to the unit price</b>						
EC	EC fan (included in versions C, C(S), BT, SSL – standard on 0285 CC with modulating control as standard). DC control included	£ 1.772	1.772	1.772	2.080	Standard
<b>FACTORY-MOUNTED ACCESSORIES</b>						
C	Ductable version	£ 2.427	2.427	2.427	3.075	3.075
C(S)	Ductable version + Soundproofing	£ 2.919	2.919	3.120	3.768	3.768
CC	On-off pressure-based condensation control down to -15 °C	£	Available only with EC			Standard
CM	Serial communication module for Modbus	£ 833	833	833	833	833
CT	On-off pressure-based condensation control down to 0 °C	£	Standard			--
DSF	Phase sequence and failure monitoring device	£	Standard			
DSFR	Sequence and phase-failure control device with undervoltage and overvoltage relay	£ 385	385	385	385	385
FE	EMC electrical filter for auxiliary devices	£	Standard			
FL	Flow switch	£	Standard			
GI	System management module	£ 482	482	482	482	482
HP LP	High and low pressure transducers with values shown on display	£	Standard			
IM	Magnetic circuit breakers on compressors and fans	£ 758	758	758	758	758
KA1	Adhesive resistance exchanger	£ 339	339	339	339	339
MPI	Integral protection module for each compressor	£	Standard			
PS	Single circulation pump	£ 1.464	1.464	1.464	1.572	1.572
SL	Unit silencing	£ 493	493	693	693	693
SSL	Super soundproofing with EC fan and DC condensation control down to -15 °C	£ 2.388	2.388	2.695	3.620	2.465
TR1	Microchannel coil with Aero surface treatment	£ 2.003	2.003	3.158	4.005	4.005
VEV	Electronic thermostat + bypass solenoid valve for low water and/or air temperatures	£	Standard			

<b>HWA1-A/H</b>		<b>0140</b>	<b>0147</b>	<b>0260</b>	<b>0273</b>	<b>0285</b>
HWA1-A/H	Chiller and reversible heat pump	£ 18.712	22.028	26.495	28.960	32.349
<b>FACTORY-MOUNTED ACCESSORIES</b>						
EC	EC fan (included in versions C, BT, SSL – standard on 0285 CC with factory-fitted modulation). Including CC control	£ 1.772	1.772	1.772	Standard	
C	Ductable version	£ 2.427	2.427	2.427	3.075	3.075
C(S)	Ductable version + Soundproofing	£ 2.919	2.919	3.120	3.768	3.768
CC	On-off pressure-based condensation control down to -15 °C	£	Available only with EC			Standard
CM	Serial communication module for Modbus	£ 851	851	851	851	851
CT	On-off pressure-based condensation control down to 0 °C	£ 2.356	3.639	4.614	--	--
DSF	Phase sequence and failure monitoring device	£	Standard			
DSFR	Sequence and phase-failure control device with undervoltage and overvoltage relay	£ 385	385	385	385	385
FE	EMC electrical filter for auxiliary devices	£	Standard			
FL	Flow switch	£	Standard			
GI	System management module	£ 482	482	482	482	482
HP LP	High and low pressure transducers with values shown on display	£	Standard			
IM	Magnetic circuit breakers on compressors and fans	£ 758	758	758	758	758
KA	Heat exchanger resistance + base	£ 339	339	339	339	339
MPI	Integral protection module for each compressor	£	Standard			
PS	Single circulation pump	£ 1.464	1.464	1.464	1.572	1.572
SL	Unit silencing	£ 493	493	693	693	693
SSL	Super soundproofing with EC fan and DC condensation control down to -15 °C	£ 2.388	2.388	2.695	3.620	2.465
TR2	Cu/Al coil with Silver Line anti-corrosion treatment - Cu	£ 2.003	2.003	3.158	4.005	4.005
VEV	Electronic thermostat + bypass solenoid valve for low water and/or air temperatures	£	Standard			

<b>ACCESSORIES SUPPLIED SEPARATELY HWA1-A &amp; HWA1-A/H</b>		<b>Code</b>	<b>£</b>
AG	Anti-vibration mounts	015908010050	233
Hi-TV415	Hi-touch control	010312300001	640
i-CR2	Wall-mounted remote control		319
SAS	Remote sensor	0110321000001	47
FY	Y-strainer	015908010056	143

For accessories of the DAS monitoring system (ISK, LNC, OVPN), see the chapter "Connection devices for Maxa DAS supervision system."

# HWA1-A 02106-04349



## Air-cooled water chiller with axial fans

106 kW-349 kW

The water chillers have been designed for commercial and industrial applications; they are very compact yet equipped with large-surface air-side heat exchangers. They therefore ensure high efficiency, with EER values among the highest in their category.

The use of high-efficiency, particularly robust scroll compressors, together with the patented oil recovery and distribution system used on tandem circuits, guarantees high reliability and consistent performance. Available in 12 sizes.



**Casing:** All units in the series feature a structure suitable for outdoor installation, made of hot-dip galvanized steel sheet coated with polyester powder paint in RAL 7035 / RAL 3020 (only for some components) to ensure optimal resistance to atmospheric agents. All screws and inserts are made of galvanized steel.

**Compressors:** of the scroll type, expressly designed to operate with R410A, mounted on rubber anti-vibration supports. The crankcase heater, which is always present, is activated when the compressor is stopped and is disabled when it restarts.

**Air-side heat exchangers:** entirely made of aluminum using microchannel technology, which significantly reduces both air-side pressure drops and refrigerant charge, while at the same time ensuring higher heat transfer capacity for the same frontal surface area compared to traditional heat exchangers.

**User-side heat exchangers:** of the brazed plate type and made of AISI 304 stainless steel for single-circuit units and AISI 316 for dual-circuit units, factory-insulated with closed-cell material, and can be equipped with an electric antifreeze heater (optional accessory KA). A differential pressure switch, installed on the water side, ensures the presence of water flow, preventing ice formation inside.

**Fans:** axial type with airfoil blades. They are statically and dynamically balanced and supplied complete with protective guard and inlet/outlet nozzles with double flared profile, specially shaped to increase efficiency and reduce noise. The motor has an IP54 protection rating according to CEI EN 60529. The electric motor used is modulation-controlled, with a directly coupled EC brushless motor and equipped with integrated thermal protection.

**Refrigeration circuit :** manufactured using components from leading international companies and in accordance with UNI EN 13134. The refrigerant gas is R410A. In its basic version, the refrigeration circuit includes: electronic expansion valve, service valves for maintenance and inspection, safety device compliant with current regulations (high- and low-pressure switch), refrigerant safety valve, pressure transducers for accurate measurement of evaporation and condensation pressures, cartridge-type dehydrator filter, liquid sight glass for checking the refrigerant charge, solenoid valve, and shut-off valves.

**Electrical panel:** fully manufactured and wired in compliance with standard EN 60204, comprising a power section and a control section. The degree of protection of the electrical panel is IP54. The electrical

panel is equipped with a terminal block with volt-free contacts for remote ON-OFF.

**Control system :** all units are equipped with a microprocessor-based control board featuring a superheat control logic managed according to the signals sent by the pressure transducers and temperature probes. The CPU also controls the following functions: water temperature regulation, antifreeze protection, compressor start-up and timing, fan and circulation pump management (where present), alarm reset, alarm indication, and operation status LEDs.

**Control and protection devices:** all units are equipped with the following control and protection devices: phase monitor complete with minimum and maximum voltage relay, which stops the unit if the phase sequence is incorrect or the voltage of at least one phase differs by more than 15% from the others; flow water temperature sensor (with antifreeze function); return water temperature sensor (both installed inside the heat exchanger); low-pressure transducer; high-pressure transducer; discharge temperature sensor on the compressors; safety valve on both the low- and high-pressure sides; suction temperature sensor on the compressors; outdoor air temperature sensor; fan thermal protection; thermal protection on each compressor; water-side differential pressure switch protecting the evaporator; manual reset high-pressure switch installed on the compressor discharge line.

**Hydraulic circuit :** the chillers can be supplied with an integrated hydronic module which, in addition to differential pressure switches, includes a single or twin pump (one serving as backup for the other) with AC motor, suitable for chilled water operation and directly managed by the on-board unit control. It is also possible to install an internal buffer tank with external insulation made of closed-cell expanded material, with capacity sized to prevent excessive compressor start-stop cycles.

## Operating Areas

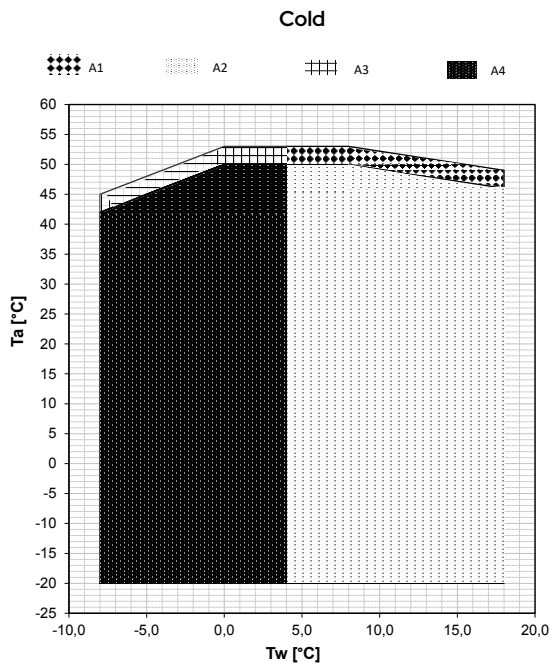

## Accessories

### Factory-installed

- **KA1\*** – Antifreeze heater for heat exchanger and pump (if present) – electric heating element installed on the front face of the plate heat exchanger, which is activated when the water temperature inside the exchanger falls below +4°C, and electric heating element that protects the pump motor at low temperatures.
- **KA2\*** – Antifreeze protection for heat exchanger, pump and tank (if present) – includes KA1 – in addition to accessory KA1, an immersion heater is added in the tank. The kit consists of: an armored electric heater in AISI 321, a programmable digital temperature controller and a contactor.
- **SL\*\*** – Silenced version. The silenced unit (equipped with the SL accessory) features an innovative thermo-acoustic jacket on the compressors. This insulation allows a noise reduction of up to 10% at certain compressor rotational frequencies. The special multilayer structure provides thermal insulation that, at very low temperatures, reduces losses by up to 2% compared to standard insulation.
- **SSL\*\*** – Super-silenced version. The super-silenced unit (equipped with the SSL accessory) includes, in addition to the thermo-acoustic enclosure on the compressors, a special diffuser mounted on the fan. This diffuser increases the fan's efficiency, allowing its speed to be reduced, thereby lowering sound pressure level and energy consumption. In this way, substantial electrical energy savings can be achieved for each fan.
- **C\*\*** – Ductable version. With the ductable version, the diffuser is used to take advantage of the higher available pressure of the fan and, if required, to duct the air discharge.
- **C(S)\*\*** – Ductable version with jackets. In addition to the ductable version, thermo-acoustic jackets are installed on the compressors.
- **PS\*\*\*** – Reversible heat pump, heating-only version with standard head.
- **PSAP\*\*\*** – Reversible heat pump, high head pump-only version.
- **PD\*\*\*** – Reversible heat pump, dual-pump version with standard head.
- **PDAP\*\*\*** – Reversible heat pump, dual high-head pump version.
- **PS-SI\*\*\*** – Reversible heat pump, standard head pump version + tank
- **PSAP-SI\*\*\*** – Reversible heat pump, high-head pump version with storage tank.
- **PD-SI\*\*\*** – Reversible heat pump, dual-pump version with standard head + storage tank.
- **PDAP-SI\*\*\*** – Reversible heat pump with dual high-head pump configuration and storage tank.
- **TE1** – Special mechanical seal for glycol content above 40% – for water-glycol mixtures with a glycol mass fraction greater than 40% and up to 50%, a different mechanical seal is used to ensure the correct operation of the electric pump.
- **TR1** – Microchannel coil with Aero surface treatment. The treatment consists of spraying a special water-based coating, formulated with new resins offering extremely high chemical resistance. The product is flexible to withstand thermal contractions and expansions, UV-resistant, dirt-repellent, mechanically resistant, with very limited reduction in heat transfer and virtually no impact on air-side pressure drops. The treatment withstands 6,000 h according to ASTM B117.
- **DS** – The desuperheater includes the addition of a brazed plate heat exchanger made of AISI 316 stainless steel, factory-insulated using closed-cell material.
- **BT** – The BT accessory allows the operating range of the water

\*\* Accessories not usable simultaneously

\*\*\* Accessories not usable simultaneously

\*\*\* Accessories not usable simultaneously

## Accessories

temperature to be extended down to  $-8^{\circ}\text{C}$ . In this case, it is necessary to use a water-glycol mixture.

- **EC** - Modulating EC fan. Includes CC function, condensing pressure control down to  $-20^{\circ}\text{C}$ . Mandatory accessory for cooling-only versions, comfort applications, EU market.
- **CC** - Condensation control down to  $-20^{\circ}\text{C}$ . Includes the EC accessory.
- **CT** - Condensation control down to  $-10^{\circ}\text{C}$ .
- **GR1** - Anti-intrusion kit for the refrigerant circuit compartment - fitted on the refrigerant circuit compartment to prevent foreign objects from entering the structure.
- **GR2** - Battery compartment anti-intrusion kit - wire mesh to prevent the entry of foreign objects into the coil and to protect the coil from accidental contact by people or objects.
- **GR3** - Anti-intrusion kit for the refrigeration circuit compartment and anti-intrusion kit for the battery compartment.
- **IM** - Circuit breakers on compressors and fans - overcurrent switches applied to compressors and fans, protecting the components from faults caused by possible current spikes.
- **SS** - Soft starter - electronic static starter for inrush current management, installed inside the electrical panel; it allows a reduction of inrush current and of mechanical wear on the motor windings.
- **LQ** - Internal switchboard lights - light for illuminating the interior of the electrical panel, facilitating maintenance for the operator.
- **SH** - Schuko socket (with MCB) - convenience socket located in the electrical panel (maximum 16 A), protected against overloads and short circuits by a miniature circuit breaker.
- **RFM** - Discharge and suction service valve on compressors - shut-off valve installed on the compressor suction and discharge lines, which simplifies maintenance by preventing the need to recover the refrigerant from the entire unit.
- **2SFV** - Changeover valve with double safety valve - the changeover valve allows alternating use of two safety valves, facilitating periodic inspection or replacement while ensuring system operation and maintaining the safety system.
- **KS** - Lifting bracket kit - facilitates lifting and positioning of the unit.
- **CM** - BMS connectivity setup - ModBus protocol included - accessory that enables the connection of the unit to external controllers via serial cable with RS-485 electrical standard and ModBus RTU protocol.

### Provided separately

- **AG** - Rubber anti-vibration kit - designed to prevent vibration transmission to the structure; they are to be installed beneath the unit, in the designated mounting holes.
- **AM** - Spring anti-vibration kit - designed to prevent transmission of vibrations to the structure; they must be installed underneath the unit, in the designated holes.
- **FY** - Y-strainer - contains a stainless steel mesh screen (500  $\mu\text{m}$  filtration) that collects solid materials present in the water. Filtration prevents blockage and/or damage to the devices installed downstream of the strainer. Alternatively, it is possible to install a dirt separator that ensures a filtration level not greater than 1 mm (in this case, it is no longer necessary to install the Y-strainer).
- **SAS** - Remote system probe.
- **RV** - Grooved connection joint. To facilitate installation, a carbon steel pipe nipple can be supplied, featuring on one end a grooved connection compatible with the one on the unit and complete with the appropriate coupling for the connection, and on the other end a G 1" 1/2 M threaded connection. The kit consists of 2 nipples and 2 grooved connections to connect the nipples to the unit.
- **ISK\*\*** - USB/RS485 serial converter - interface device capable of reading and writing control registers via the RS485 standard and converting them to a USB port that can be connected to any supervision system.
- **LNC\*\*** - LAN-Wi-Fi router - device that allows the unit to be connected to a local network via Ethernet cable or Wi-Fi coverage for remote monitoring.
- **OVPN\*\*** - 3G LAN-Wi-Fi router with VPN tunnel - device that allows the unit to be connected remotely with an industrial router using the secure OPENVPN service.
- **i-CR2\*\*** - Wall-mounted remote control - Modbus remote controller with negative LCD and capacitive keys. The device is intended to be used as a remote unit keypad with local temperature sensing and replicates the functions of the on-board unit controller.
- **Hi-TV415\*\*** - Color touch screen wired remote controller for the centralized management of a cascade of chillers/heat pumps, for up to 7 units.



**i-CR2**  
Wall-mounted  
remote control  
**ACCESSORY**



**Hi-TV415**  
Touch screen remote  
controller for cascade  
management (max 7 units)  
**ACCESSORY**

## Dimensional Drawings

HWA1-A 02106-04349

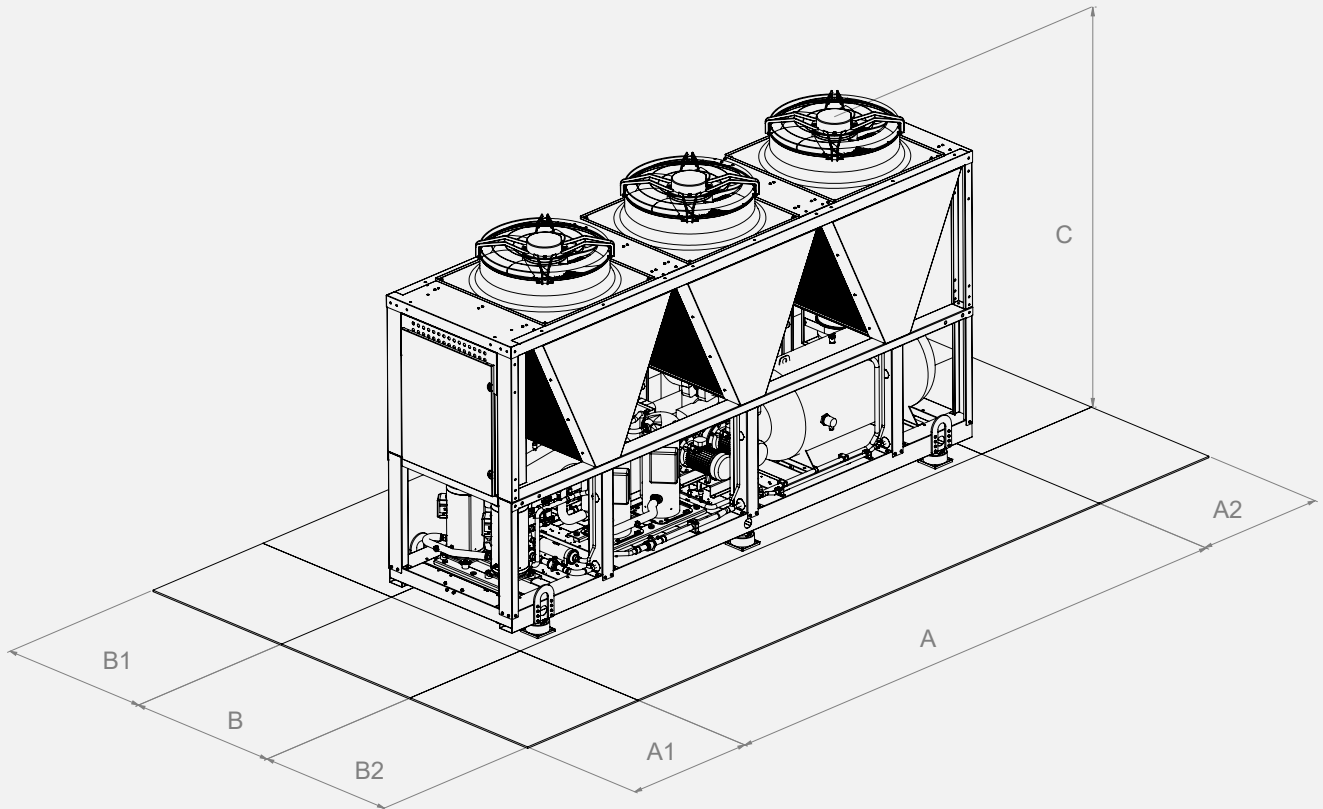

Model	Dimensions			Clearances				User heat exchanger	
	A [mm]	B [mm]	C [mm]	A1[mm]	A2 [mm]	B1 [mm]	B2 [mm]	Type	Ø *
02106	2860	1100	2350	1000	800	1000	1000	Victaulic	DN65 (2" 1/2)
02120	2860	1100	2350	1000	800	1000	1000	Victaulic	DN65 (2" 1/2)
02128	2860	1100	2350	1000	800	1000	1000	Victaulic	DN65 (2" 1/2)
02140	4060	1100	2350	1000	800	1000	1000	Victaulic	DN65 (2" 1/2)
04155	4060	1100	2350	1000	800	1000	1000	Victaulic	DN80 (3")
04177	4060	1100	2350	1000	800	1000	1000	Victaulic	DN80 (3")
04184	4060	1100	2350	1000	800	1000	1000	Victaulic	DN80 (3")
04209	2860	2200	2350	1000	800	1000	1000	Victaulic	DN80 (3")
04239	2860	2200	2350	1000	800	1000	1000	Victaulic	DN80 (3")
04258	2860	2200	2350	1000	800	1000	1000	Victaulic	DN80 (3")
04305	4060	2200	2350	1000	800	1000	1000	Victaulic	DN80 (3")
04349	4060	2200	2350	1000	800	1000	1000	Victaulic	DN80 (3")

\* It depends on the hydronic version – refer to the technical bulletin

			02106	02120	02128	02140	04155	04177	
<b>Cooling</b>	Cooling capacity (1)	kW	105	119	130	139	155	176	
	Total absorbed power (1)	kW	33,5	38,3	44,2	44,3	49,9	56,7	
	EER (1)	W/W	3,13	3,10	2,93	3,15	3,11	3,10	
	Cooling capacity (2)	kW	139	155	164	185	204	230	
	Total absorbed power (2)	kW	35,7	40,8	46,8	47,5	52,9	60,9	
	EER (2)	W/W	3,88	3,79	3,50	3,89	3,87	3,77	
	SEER (3)	W/W	4,13	4,12	4,11	4,27	4,11	4,11	
	IPLV (9)		4,99	5,09	4,71	5,02	5,13	5,13	
	Cooling capacity (8)	kW	61,9	70,6	77,8	82,0	91,5	103	
	Total absorbed power (8)	kW	29,9	34,1	39,3	39,5	45,4	50,8	
	EER (8)	W/W	2,07	2,07	1,98	2,08	2,02	2,04	
	Water flow rate (1)	l/s	5,0	5,7	6,2	6,7	7,4	8,4	
Pressure drops in the heat exchanger, user side (1)	kPa	31,68	39,65	24,67	41,78	45,07	40,44		
<b>Compressor</b>	Compressor type		SCROLL						
	Refrigerant oil (type)		Emkarate RL 32 3MAF						
	No. of compressors	No.	2	2	2	2	4	4	
	Standard capacity steps	No.	2	3	2	3	4	4	
	Oil charge (Circuit 1)	l	4,44 + 4,44	4,44 + 4,44	4,44 + 4,44	6,3 + 4,44	3,25 + 3,25	4,44 + 4,44	
	Oil load (Circuit 2)	l	-	-	-	-	3,25 + 3,25	3,25 + 3,25	
	Refrigerant circuits	No.	1	1	1	1	2	2	
<b>Refrigerant</b>	Type		R410A						
	Refrigerant charge (Circuit 1) (4)	kg	10,5	10,5	10,5	15	13,0	13,0	
	Refrigerant charge (Circuit 2) (4)	kg	-	-	-	-	10,5	10,5	
	Tons of CO <sub>2</sub> equivalent (4)	Ton	21,9	21,9	21,9	31,3	49,1	49,1	
	Design pressure (high/low)	bar	40,5/4	40,5/4	40,5/4	40,5/4	40,5/4	40,5/4	
<b>Outdoor zone fans</b>	Fan types		AXIAL						
	No. of fans	No.	2	2	2	3	3	3	
	Rated power (1)	kW	1,5	1,5	1,5	1,4	1,4	1,4	
	Maximum power	kW	3,8	3,8	3,8	5,7	5,7	5,7	
	Maximum absorbed current	A	3,9	3,9	3,9	3,9	3,9	3,9	
	Standard air flow rate	l/s	10614	10714	11143	14649	14467	15868	
<b>Internal heat exchanger</b>	Internal heat exchanger type		PHE – PLATE TYPE						
	No. of indoor heat exchangers	No.	1	1	1	1	1	1	
	Water content	l	6,87	6,87	9,90	7,88	9,30	11,40	
<b>Hydraulic circuit</b>	Max water-side pressure	bar	12	12	12	12	12	12	
	Max pressure of hydronic kit (safety valve setting)	bar	6	6	6	6	6	6	
	Water connections		2" 1/2	2" 1/2	2" 1/2	2" 1/2	3"	3"	
	Minimum system water content (5)	l	427	535	535	699	409	533	
<b>Sound data</b>	Sound power (6)	dB (A)	86 std 85 SL 83 SSL	86 std 85 SL 83 SSL	87 std 86 SL 84 SSL	87 std 86 SL 84 SSL	87 std 86 SL 84 SSL	88 std 87 SL 85 SSL	
		Sound pressure (7)	dB (A)	54 std 53 SL 51 SSL	54 std 53 SL 51 SSL	55 std 54 SL 52 SSL	54,9 std 53,9 SL 51,9 SSL	54,9 std 53,9 SL 51,9 SSL	55,9 std 54,9 SL 52,9 SSL
<b>Electrical data</b>	Power supply		400V/3P/50Hz						
	Maximum power input version without accessories	kW	48,9	55,0	61,1	66,9	82,4	87,4	
	Maximum absorbed current version without accessories	A	83,0	93,4	103,8	113,5	139,9	148,3	
	Maximum inrush current version without accessories	A	285,6	332,3	342,7	358,1	279,9	350,9	
<b>Dimensions and weights</b>	A - Length	mm	2860	2860	2860	4060	4060	4060	
	B - Depth	mm	1100	1100	1100	1100	1100	1100	
	C - Height	mm	2350	2350	2350	2350	2350	2350	
	Net shipping weight	kg	1080	1080	1090	1510	1620	1620	
	Operating weight	kg	1090	1090	1100	1520	1630	1630	

(1) Cooling: outdoor air temperature 35°C; inlet/outlet water temperature 12/7°C.

(2) Cooling: outdoor air temperature 35°C; inlet/outlet water temperature 23/18°C.

(3) Cooling: inlet/outlet water temperature 7/12°C.

(4) Data is indicative and subject to change. For the correct value, always refer to the technical label on the unit.

(5) The indicated volume refers to the total required amount; the designer must meet this requirement by taking into account the quantity already contained within the unit, depending on the selected hydronic kit (please refer to the technical data sheet to check this value).

(6) Condition (1); value determined on the basis of measurements carried out in accordance with UNI EN ISO 9614-1.

(7) Value calculated from the sound power level using ISO 3744:2010, referenced to a distance of 10 m from the unit.

(8) Cooling BT version: outdoor air temperature 35°C, internal heat exchanger water temperature = -3/-8°C. Fluid treated with 35% ethylene glycol.

(9) Calculated according to AHRI 551/591 (SI) standard.

The stated performance data are indicative and may be subject to change. Furthermore, the capacities declared at points (1), (2), (8) refer to the instantaneous power in accordance with UNI EN 14511. The value declared at point (3) is determined in accordance with UNI EN 14825.

			04184	04209	04239	04258	04305	04349	
<b>Cooling</b>	Cooling capacity (1)	kW	182	208	238	257	305	348	
	Total absorbed power (1)	kW	62,9	67,1	76,8	88,5	98,3	112	
	EER (1)	W/W	2,90	3,10	3,10	2,90	3,10	3,10	
	Cooling capacity (2)	kW	239	277	314	333	405	458	
	Total absorbed power (2)	kW	67,8	71,6	81,9	94,6	105	121	
	EER (2)	W/W	3,52	3,87	3,84	3,52	3,85	3,78	
	SEER (3)	W/W	4,10	4,14	4,24	4,10	4,16	4,12	
	IPLV (9)		4,95	4,99	4,94	4,37	4,92	5,05	
	Cooling capacity (8)	kW	109	123	144	158	184	211	
	Total absorbed power (8)	kW	55,8	59,7	68,8	79,4	88,5	101	
	EER (8)	W/W	1,95	2,06	2,09	1,99	2,08	2,10	
	Water flow rate (1)	l/s	8,7	9,9	11,4	12,3	14,6	16,6	
Pressure drops in the heat exchanger, user side (1)	kPa	43,31	55,47	42,98	49,56	40,76	52,52		
<b>Compressor</b>	Compressor type		SCROLL						
	Refrigerant oil (type)		Emkarate RL 32 3MAF						
	No. of compressors	No.	4	4	4	4	4	4	
	Standard capacity steps	No.	4	4	6	4	6	4	
	Oil charge (Circuit 1)	l	4,44 + 4,44	4,44 + 4,44	4,44 + 4,44	4,44 + 4,44	4,44 + 6,3	6,3 + 6,3	
	Oil load (Circuit 2)	l	4,44 + 4,44	4,44 + 4,44	4,44 + 4,44	4,44 + 4,44	4,44 + 6,3	6,3 + 6,3	
	Refrigerant circuits	No.	2	2	2	2	2	2	
<b>Refrigerant</b>	Type		R410A						
	Refrigerant charge (Circuit 1) (4)	kg	13,0	13,0	13,5	13,5	19,5	20,0	
	Refrigerant charge (Circuit 2) (4)	kg	10,5	13,0	13,5	13,5	19,5	20,5	
	Tons of CO <sub>2</sub> equivalent (4)	Ton	49,1	54,3	56,4	56,4	81,4	84,6	
	Design pressure (high/low)	bar	40,5/4	40,5/4	40,5/4	40,5/4	40,5/4	40,5/4	
<b>Outdoor zone fans</b>	Fan types		AXIAL						
	No. of fans	No.	3	4	4	4	6	6	
	Rated power (1)	kW	1,5	1,4	1,5	1,5	1,4	1,5	
	Maximum power	kW	5,7	7,6	7,6	7,6	11,4	11,4	
	Maximum absorbed current	A	3,9	3,9	3,9	3,9	3,9	3,9	
	Standard air flow rate	l/s	15892	20647	20471	22231	29279	33255	
<b>Internal heat exchanger</b>	Internal heat exchanger type		PHE – PLATE TYPE						
	No. of indoor heat exchangers	No.	1	1	1	1	1	1	
	Water content	l	11,40	11,40	15,50	22,10	22,10	22,10	
<b>Hydraulic circuit</b>	Max water-side pressure	bar	12	12	12	12	12	12	
	Max pressure of hydronic kit (safety valve setting)	bar	6	6	6	6	6	6	
	Water connections		3"	3"	3"	3"	3"	3"	
	Minimum system water content (5)	l	533	533	669	669	874	874	
<b>Sound data</b>	Sound power (6)	dB (A)	88 std 87 SL 85 SSL	88 std 87 SL 85 SSL	88 std 87 SL 85 SSL	88 std 87 SL 85 SSL	88 std 87 SL 85 SSL	90 std 89 SL 87 SSL	
		Sound pressure (7)	dB (A)	55,9 std 54,9 SL 52,9 SSL	55,9 std 54,9 SL 52,9 SSL	55,9 std 54,9 SL 52,9 SSL	55,9 std 54,9 SL 52,9 SSL	55,8 std 54,8 SL 52,8 SSL	57,8 std 56,8 SL 54,8 SSL
<b>Electrical data</b>	Power supply		400V/3P/50Hz						
	Maximum power input version without accessories	kW	90,9	97,8	110,0	122,3	146,0	165,8	
	Maximum absorbed current version without accessories	A	154,3	166,0	186,8	207,6	247,8	281,4	
	Maximum inrush current version without accessories	A	356,9	368,6	425,7	446,5	492,4	526,0	
<b>Dimensions and weights</b>	A - Length	mm	4060	2860	2860	2860	4060	4060	
	B - Depth	mm	1100	2200	2200	2200	2200	2200	
	C - Height	mm	2350	2350	2350	2350	2350	2350	
	Net shipping weight	kg	1620	1950	1960	1960	2670	2850	
	Operating weight	kg	1630	1960	1970	1980	2690	2870	

(1) Cooling: outdoor air temperature 35°C; inlet/outlet water temperature 12/7°C.

(2) Cooling: outdoor air temperature 35°C; inlet/outlet water temperature 23/18°C.

(3) Cooling: inlet/outlet water temperature 7/12°C.

(4) Data is indicative and subject to change. For the correct value, always refer to the technical label on the unit.

(5) The indicated volume refers to the total required amount; the designer must meet this requirement by taking into account the quantity already contained within the unit, depending on the selected hydronic kit (please refer to the technical data sheet to check this value).

(6) Condition (1); value determined on the basis of measurements carried out in accordance with UNI EN ISO 9614-1.

(7) Value calculated from the sound power level using ISO 3744:2010, referenced to a distance of 10 m from the unit.

(8) Cooling BT version: outdoor air temperature 35°C, internal heat exchanger water temperature = -3/-8°C. Fluid treated with 35% ethylene glycol.

(9) Calculated according to AHRI 551/591 (SI) standard.

The stated performance data are indicative and may be subject to change. Furthermore, the capacities declared at points (1), (2), (8) refer to the instantaneous power in accordance with UNI EN 14511. The value declared at point (3) is determined in accordance with UNI EN 14825.

## Price list

HWA1-A			02106	02120	02128	02140	04155	04177
HWA1-A	Cooling only	£	37.723	40.044	41.646	47.210	49.573	52.730
<b>FACTORY-MOUNTED ACCESSORY MANDATORY: Standard EC fan for ERP regulation to be added to the unit price</b>								
EC	EC fan (included in C, BT, SSL versions). DC control included	£	2.076	2.076	2.076	2.855	2.336	2.076
<b>FACTORY-MOUNTED ACCESSORIES</b>								
2SFV	Double safety valve	£	415	415	415	415	831	831
BT	Cooling only BT version (EC accessory already included)	£	5.120	5.168	5.375	6.461	6.245	7.734
C	Ductable version (EC accessory is already included for these versions)	£	3.374	3.374	3.374	5.450	5.450	5.450
C(S)	Ductable version with compressor soundproofing	£	4.361	4.466	4.466	6.614	6.965	6.965
CC	Condensation control down to -20°C (Only with EC fans)	£	2.076	2.076	2.076	2.855	2.336	2.076
CM	Serial communication module for Modbus	£	825	825	825	825	825	825
CT	Condensation control down to -10°C	£	379	379	379	379	379	561
DS	Cooling only with partial heat recovery (desuperheater circuit)	£	3.974	4.355	4.529	7.031	7.380	6.347
GR1	Anti-intrusion kit for refrigeration circuit compartment	£	2.165	2.165	2.165	2.644	2.644	2.644
GR2	Anti-intrusion battery compartment kit	£	753	753	753	753	753	753
GR3	Anti-intrusion kit for battery compartment and circuit	£	2.918	2.918	2.918	3.396	3.396	3.396
IM	Magnetic circuit breakers on compressors and fans	£	844	844	844	1.479	1.713	1.713
KA1	Adhesive heater for heat exchanger + pump heater (if present). Not available for units with tank	£	246	246	246	246	246	246
KA2	Adhesive heater exchanger + pump heater (if present) + heater	£	909	909	909	909	909	909
KS	Lifting bracket kit	£	285	285	285	285	285	285
LQ	Internal electrical panel lights	£	454	454	454	454	454	454
PD	Twin pump, standard head	£	7.007	7.007	7.007	7.865	7.865	8.383
PD-SI	Dual standard-head pump + tank	£	10.245	11.614	10.245	11.809	11.679	11.679
PDAP	Dual high-head pump	£	8.046	8.046	8.046	9.343	9.603	9.603
PDAP-SI	Double high-head pump + tank	£	11.543	12.912	11.543	13.626	13.496	13.496
PS	Standard head pump	£	3.763	3.763	3.763	5.255	5.255	5.255
PS-SI	Standard head pump + tank	£	7.332	7.332	7.332	8.500	7.786	7.786
PSAP	High-head pump	£	4.802	4.802	4.802	6.034	6.034	6.034
PSAP-SI	High head pump + tank	£	8.371	8.371	8.371	9.538	8.824	8.824
RFM	Delivery and suction valves for compressors	£	410	410	410	818	818	818
SH	Schuko socket (with miniature circuit breaker)	£	272	272	272	272	272	272
SL	Silenced version	£	987	1.092	1.092	1.163	1.513	1.513
SS	Soft starter	£	3.715	4.015	4.015	4.955	5.872	5.872
SSL	Super-silent version (EC accessory is already included for these versions).	£	3.499	3.499	3.499	4.848	5.320	5.710
TE1	Special mechanical seal for glycol >40%	£	364	364	364	559	559	559
TR1	Microchannel coil with Aero surface treatment	£	3.828	3.828	3.828	5.450	8.046	8.046
<b>ACCESSORIES SUPPLIED SEPARATELY</b>								
AG	Rubber anti-vibration mounts	£	727	727	727	1.078	1.078	1.078
AM	Spring anti-vibration mounts	£	1.873	2.485	2.485	2.485	2.485	2.485
FY	Y-strainer	£	175	175	175	251	251	251
Hi-TV415	Touchscreen remote control	£	640	640	640	640	640	640
i-CR2	Wall-mounted remote control	£	319	319	319	319	319	319
RV	Starter kit consisting of 2 jaws and 2 plain stubs	£	125	125	125	125	125	125
SAS	Remote sensor	£	47	47	47	47	47	47

## Price list

HWA1-A			04184	04209	04239	04258	04305	04349
HWA1-A	Cooling only	£	67.410	68.744	70.464	80.834	88.197	100.262
<b>FACTORY-MOUNTED ACCESSORY MANDATORY: Standard EC fan for ERP regulation to be added to the unit price</b>								
EC	EC fan (included in C, BT, SSL versions). DC control included	£	2.076	2.855	2.855	2.855	5.191	5.191
<b>FACTORY-MOUNTED ACCESSORIES</b>								
2SFV	Double safety valve	£	831	831	831	831	831	831
BT	Cooling only BT version (EC accessory already included)	£	6.660	6.568	6.721	6.929	7.407	5.532
C	Ductable version (EC accessory is already included for these versions)	£	5.450	6.566	6.566	6.566	10.642	11.939
C(S)	Ductable version with compressor soundproofing	£	7.086	8.280	8.416	8.416	12.601	13.898
CC	Condensation control down to -20°C (Only with EC fans)	£	2.076	2.855	2.855	2.855	5.191	5.191
CM	Serial communication module for Modbus	£	825	825	825	825	825	825
CT	Condensation control down to -10°C	£	561	561	561	561	561	561
DS	Cooling only Partial Heat Recovery (Desuperheater Circuit)	£	5.654	7.139	5.713	7.871	8.019	6.858
GR1	Anti-intrusion kit for refrigeration circuit compartment	£	2.644	2.769	2.769	2.769	3.247	3.247
GR2	Anti-intrusion battery compartment kit	£	1.070	1.070	1.362	1.362	1.622	1.622
GR3	Anti-intrusion kit for battery compartment and circuit	£	3.714	3.839	4.132	4.132	4.870	4.870
IM	Magnetic circuit breakers on compressors and fans	£	1.713	1.713	1.713	1.713	2.531	2.984
KA1	Adhesive heater for heat exchanger + pump heater (if present). Not available for units with tank	£	246	246	246	246	246	246
KA2	Adhesive heater exchanger + pump heater (if present) + heater	£	909	909	909	909	909	909
KS	Lifting bracket kit	£	285	285	285	285	285	285
LQ	Internal electrical panel lights	£	454	454	454	454	454	454
PD	Twin pump, standard head	£	8.617	9.032	9.032	9.811	10.382	12.199
PD-SI	Dual standard-head pump + tank	£	14.923	15.832	16.352	16.352	17.389	18.686
PDAP	Dual high-head pump	£	9.603	9.863	9.863	10.512	11.939	12.977
PDAP-SI	Double high-head pump + tank	£	16.222	17.129	17.649	17.649	19.206	20.503
PS	Standard head pump	£	5.255	5.255	5.255	6.436	6.436	6.436
PS-SI	Standard head pump + tank	£	10.122	10.382	10.900	11.939	12.329	12.329
PSAP	High-head pump	£	6.034	6.294	6.294	7.267	7.527	7.786
PSAP-SI	High head pump + tank	£	11.160	11.420	11.939	12.977	13.366	13.366
RFM	Delivery and suction valves for compressors	£	818	818	818	818	1.151	1.151
SH	Schuko socket (with miniature circuit breaker)	£	272	272	272	272	272	272
SL	Silenced version	£	1.635	1.713	1.849	1.849	1.960	1.960
SS	Soft starter	£	7.425	7.425	7.630	8.026	9.900	11.224
SSL	Super-silent version (EC accessory is already included for these versions).	£	8.306	8.954	9.084	9.084	13.236	13.756
TE1	Special mechanical seal for glycol >40%	£	559	559	559	559	559	559
TR1	Microchannel coil with Aero surface treatment	£	8.046	7.656	7.656	7.656	10.770	10.770
<b>ACCESSORIES SUPPLIED SEPARATELY</b>								
AG	Rubber anti-vibration mounts	£	1.315	1.315	1.315	1.315	2.257	2.457
AM	Spring anti-vibration mounts	£	2.444	2.444	2.444	2.444	3.169	3.169
FY	Y-strainer	£	251	376	376	376	426	426
Hi-TV415	Touchscreen remote control	£	640	640	640	640	640	640
i-CR2	Wall-mounted remote control	£	319	319	319	319	319	319
RV	Starter kit consisting of 2 jaws and 2 plain stubs	£	125	125	125	175	175	175
SAS	Remote sensor	£	47	47	47	47	47	47
<b>STANDARD</b>								
Remote probe enablement		£	standard					
Second setpoint enable		£	standard					

For accessories of the DAS monitoring system (ISK, LNC, OVPN), see the chapter "Connection devices for Maxa DAS supervision system."

# HWA1-A/H 02109-04345



## Air/water heat pumps with axial fans

109 kW-345 kW

The air-to-water heat pumps have been designed for commercial and industrial applications; they are very compact yet equipped with large-surface air-side heat exchangers. As a result, they ensure high efficiency, with COP values among the highest in their category. The use of high-efficiency, particularly robust scroll compressors, together with the patented oil recovery and distribution system used on tandem circuits, guarantees high reliability and consistent performance. Available in 12 sizes.



**Casing:** All units in the series feature a structure suitable for outdoor installation, made of hot-dip galvanized steel sheet coated with polyester powder paint in RAL 7035 / RAL 3020 (only for some components) to ensure optimal resistance to atmospheric agents. All screws and inserts are made of galvanized steel.

**Compressors:** scroll type, specifically designed to operate with R410A, mounted on rubber anti-vibration supports. The crankcase heater, which is always present, is activated when the compressor is stopped and is disabled when it restarts.

**Air-side heat exchangers:** finned-coil type, made with copper tubes and aluminum fins with corrugated surface, suitably spaced to ensure maximum heat exchange efficiency.

**User-side heat exchangers:** of the brazed plate type and made of AISI 304 stainless steel for single-circuit units and AISI 316 for dual-circuit units, factory-insulated with closed-cell material, and can be equipped with an electric antifreeze heater (optional accessory KA). A differential pressure switch, installed on the water side, ensures the presence of water flow, preventing ice formation inside.

**Fans:** axial type with airfoil profile blades. They are statically and dynamically balanced and supplied complete with protective grille and inlet and outlet nozzles with double flared profile, specially shaped to increase efficiency and reduce noise. The motor has an IP54 protection rating in accordance with CEI EN 60529. Regulation is performed by means of voltage variators, directly controlled by the onboard unit control; this solution is particularly suitable when operation with outdoor air temperatures below  $-10^{\circ}\text{C}$  is required and is available on request for all models. As an accessory, EC fans are available, allowing the operating range to be further extended.

**Refrigerant circuit:** it is built using components supplied by leading international manufacturers and in compliance with UNI EN 13134. The refrigerant gas is R410A. In its basic configuration, the refrigerant circuit includes: electronic expansion valve, service valves for maintenance and inspection, safety device compliant with current regulations (high- and low-pressure switch), safety valve for the refrigerant, pressure transducers to accurately measure evaporation and condensation pressures, high-capacity replaceable core filter drier to prevent expansion valve blockage and remove any moisture present in the circuit, liquid sight glass for refrigerant charge monitoring, solenoid valve and shut-off valves.

In heat pump versions, the following are also included: 4-way reversing valve, liquid separator, liquid receiver, and outdoor air temperature

probe.

**Electrical panel:** fully manufactured and wired in compliance with standard EN 60204, comprising a power section and a control section. The degree of protection of the electrical panel is IP54. The electrical panel is equipped with a terminal block with volt-free contacts for remote ON-OFF.

**Control system:** all units are equipped with a microprocessor-based control board with superheat control logic managed according to the signals sent by the pressure transducers and temperature probes. The CPU also controls the following functions: water temperature regulation, antifreeze protection, compressor start-up and timing, fan and circulation pump management (where present), alarm reset, alarm signalling and operation LEDs. On request, the microprocessor can be connected to remote BMS control systems.

**Control and protection devices:** all units are equipped with the following control and protection devices: phase monitor complete with minimum and maximum voltage relay, which stops the unit if the phase sequence is incorrect or the voltage of at least one phase differs by more than 15% from the others; flow water temperature sensor (with antifreeze function); return water temperature sensor (both installed inside the heat exchanger); low-pressure transducer; high-pressure transducer; discharge temperature sensor on the compressors; safety valve on both the low- and high-pressure sides; suction temperature sensor on the compressors; outdoor air temperature sensor; fan thermal protection; thermal protection on each compressor; water-side differential pressure switch protecting the evaporator; manual reset high-pressure switch installed on the compressor discharge line.

**Hydraulic circuit:** the heat pumps in the series can be supplied with an integrated hydraulic module, which includes, in addition to differential pressure switches, a single or twin pump (one serving as a backup for the other) with AC motor, suitable for chilled water operation and directly managed by the unit's onboard controller.

It is also possible to install an internal buffer storage tank, externally insulated with closed-cell foam material and sized with an adequate capacity to prevent excessive compressor start-stop cycles.

## Operating Areas

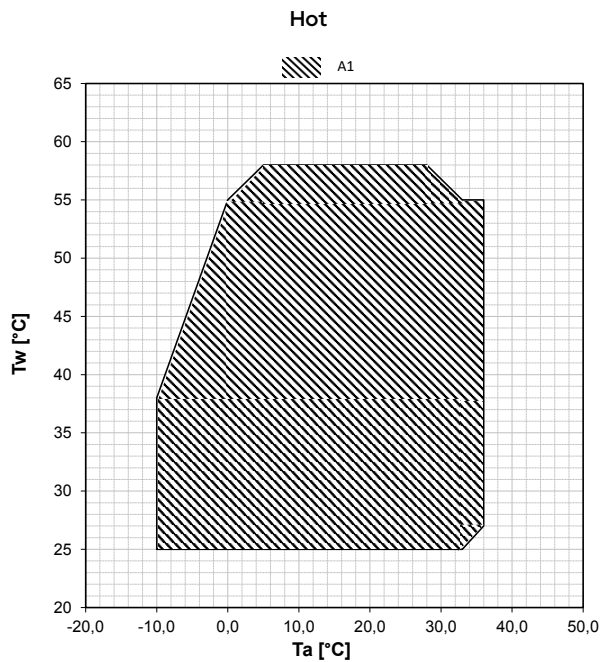

Tw: water temperature - Ta: outdoor air temperature  
A1 = HWA1-A/H heating

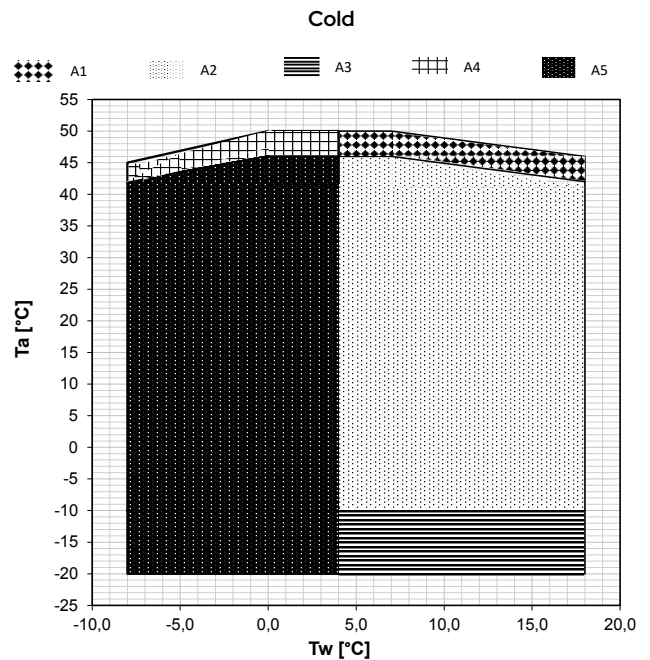

A1 = HWA1-A/H cooling partial load  
A2 = HWA1-A/H cooling  
A3 = HWA1-A/H cooling with CC accessory for condensation control down to -20°C  
A4 = HWA1-A/H BT partial load  
A5 = HWA1-A/H BT

## Accessories

### Factory-installed

- **KA1\*** – Antifreeze heater for heat exchanger and pump (if present) – electric heating element installed on the front face of the plate heat exchanger, which is activated when the water temperature inside the exchanger falls below +4°C, and electric heating element that protects the pump motor at low temperatures.
- **KA2\*** – Antifreeze protection for heat exchanger, pump and tank (if present) – includes KA1 – in addition to accessory KA1, an immersion heater is added in the tank. The kit consists of: an armored electric heater in AISI 321, a programmable digital temperature controller and a contactor.
- **SL\*\*** – Silenced version. The silenced unit (equipped with the SL accessory) features an innovative thermo-acoustic jacket on the compressors. This insulation allows a noise reduction of up to 10% at certain compressor rotational frequencies. The special multilayer structure provides thermal insulation that, at very low temperatures, reduces losses by up to 2% compared to standard insulation.
- **SSL\*\*** – Super-silenced version. The super-silenced unit (equipped with the SSL accessory) includes, in addition to the thermo-acoustic enclosure on the compressors, a special diffuser mounted on the fan. This diffuser increases the fan's efficiency, allowing its speed to be reduced, thereby lowering sound pressure level and energy consumption. In this way, substantial electrical energy savings can be achieved for each fan.
- **C\*\*** – Ductable version. With the ductable version, the diffuser is used to take advantage of the higher available pressure of the fan and, if required, to duct the air discharge.
- **C(S)\*\*** – Ductable version with jackets. In addition to the ductable version, thermo-acoustic jackets are installed on the compressors.
- **PS\*\*\*** – Reversible heat pump, heating-only version with standard head.
- **PSAP\*\*\*** – Reversible heat pump, high-head pump only version.
- **PD\*\*\*** – Reversible heat pump, dual-pump version with standard head.
- **PDAP\*\*\*** – Reversible heat pump, dual high-head pump version.
- **PS-SI\*\*\*** – Reversible heat pump with standard head pump version + tank.
- **PSAP-SI\*\*\*** – Reversible heat pump, high-head pump version with storage tank.
- **PD-SI\*\*\*** – Reversible heat pump, dual-pump version with standard head + storage tank.
- **PDAP-SI\*\*\*** – Reversible-cycle heat pump, high-head twin pump version with buffer tank.
- **TE1** – Special mechanical seal for glycol content above 40%

\*\* Accessories not usable simultaneously  
\*\*\* Accessories not usable simultaneously  
\*\*\* Accessories not usable simultaneously

## Accessories

- for water-glycol mixtures with a glycol mass fraction greater than 40% and up to 50%, a different mechanical seal is used to ensure the correct operation of the electric pump.
- **TR2** - Coil anti-corrosion treatment – thanks to this treatment, the coil becomes flexible to withstand thermal contractions and expansions, mechanically resistant, UV-protected and dirt-repellent. Heat transfer losses are very limited. The treatment ensures coil protection under virtually all environmental conditions: from coastal to rural areas, from industrial to urban zones. The treatment withstands 6,000 hours according to ASTM B117. (HWA1-A/H).
- **DS** - The desuperheater includes the addition of a brazed plate heat exchanger made of AISI 316 stainless steel, factory-insulated using closed-cell material.
- **BT** - The BT accessory allows the operating range of the water temperature to be extended down to -8°C. In this case, it is necessary to use a water-glycol mixture.
- **EC** - Modulating EC fan. Includes CC function, condensing pressure control down to -20°C. Mandatory accessory for cooling-only versions, comfort applications, EU market.
- **CC** - Condensation control down to -20°C. Includes the EC accessory.
- **CT** - Condensation control down to -10°C.
- **GR1** - Anti-intrusion kit for refrigeration circuit compartment – installed on the refrigeration circuit compartment to prevent the ingress of foreign objects into the unit.
- **GR2** - Battery compartment anti-intrusion kit – wire mesh to prevent the entry of foreign objects into the coil and to protect the coil from accidental contact by people or objects.
- **GR3** - Anti-intrusion kit for the refrigeration circuit compartment and anti-intrusion kit for the battery compartment.
- compartment.
- **IM** - Circuit breakers on compressors and fans – overcurrent switches applied to compressors and fans, protecting the components from faults caused by possible current spikes.
- **SS** - Soft starter – electronic static starter for inrush current management, installed inside the electrical panel; it allows a reduction of inrush current and of mechanical wear on the motor windings.
- **LQ** - Internal switchboard lights – light for illuminating the interior of the electrical panel, facilitating maintenance for the operator.
- **SH** - Schuko socket (with MCB) – convenience socket located in the electrical panel (maximum 16 A), protected against overloads and short circuits by a miniature circuit breaker.
- **RFM** - Discharge and suction service valve on compressors – shut-off valve installed on the compressor suction and discharge lines, which simplifies maintenance by preventing the need to recover the refrigerant from the entire unit.
- **2SFV** - Changeover valve with double safety valve – the changeover valve allows alternating use of two safety valves, facilitating periodic inspection or replacement while ensuring system operation and maintaining the safety system.
- **KS** - Lifting bracket kit – facilitates lifting and positioning of the unit.
- **CM** - BMS connectivity setup – ModBus protocol included – accessory that enables the connection of the unit to external controllers via serial cable with RS-485 electrical standard and ModBus RTU protocol.
- **ACK6** - Summer/Winter status signaling – auxiliary contactors providing a volt-free contact, allowing remote indication of the operating mode (summer/winter).

### Provided separately

- **AG** - Rubber anti-vibration kit – designed to prevent vibration transmission to the structure; they are to be installed beneath the unit, in the designated mounting holes.
- **AM** - Spring anti-vibration kit – designed to prevent transmission of vibrations to the structure; they must be installed underneath the unit, in the designated holes.
- **FY** - Y-strainer – contains a stainless steel mesh screen (500 µm filtration) that collects solid materials present in the water. Filtration prevents blockage and/or damage to the devices installed downstream of the strainer. Alternatively, it is possible to install a dirt separator that ensures a filtration level not greater than 1 mm (in this case, it is no longer necessary to install the Y-strainer).
- **SAS** - Remote system probe.
- **RV** - Grooved connection joint. To facilitate installation, a carbon steel pipe nipple can be supplied, featuring on one end a grooved connection compatible with the one on the unit and complete with the appropriate coupling for the connection, and on the other end a G 1" 1/2 M threaded connection. The kit consists of 2 nipples and 2 grooved connections to connect the nipples to the unit.
- **ISK\*\*** - USB/RS485 serial converter – interface device capable of reading and writing control registers via the RS485 standard and converting them to a USB port that can be connected to any supervision system.
- **LNC\*\*** - LAN-Wi-Fi router – device that allows the unit to be connected to a local network via Ethernet cable or Wi-Fi coverage for remote monitoring.
- **OVPN\*\*** - 3G LAN-Wi-Fi router with VPN tunnel – device that allows the unit to be connected remotely with an industrial router using the secure OPENVPN service.
- **i-CR2\*\*** - Wall-mounted remote control – Modbus remote controller with negative LCD and capacitive keys. The device is intended to be used as a remote unit keypad with local temperature sensing and replicates the functions of the on-board unit controller.
- **Hi-TV415\*\*** - Color touch screen wired remote controller for the centralized management of a cascade of chillers/heat pumps, for up to 7 units.

\*\* Accessories not usable simultaneously



**i-CR2**  
Wall-mounted  
remote control  
**ACCESSORY**



**Hi-TV415**  
Touch screen remote  
controller for cascade  
management (max 7 units)  
**ACCESSORY**

## Dimensional Drawings

HWA1-A/H 02109-04345

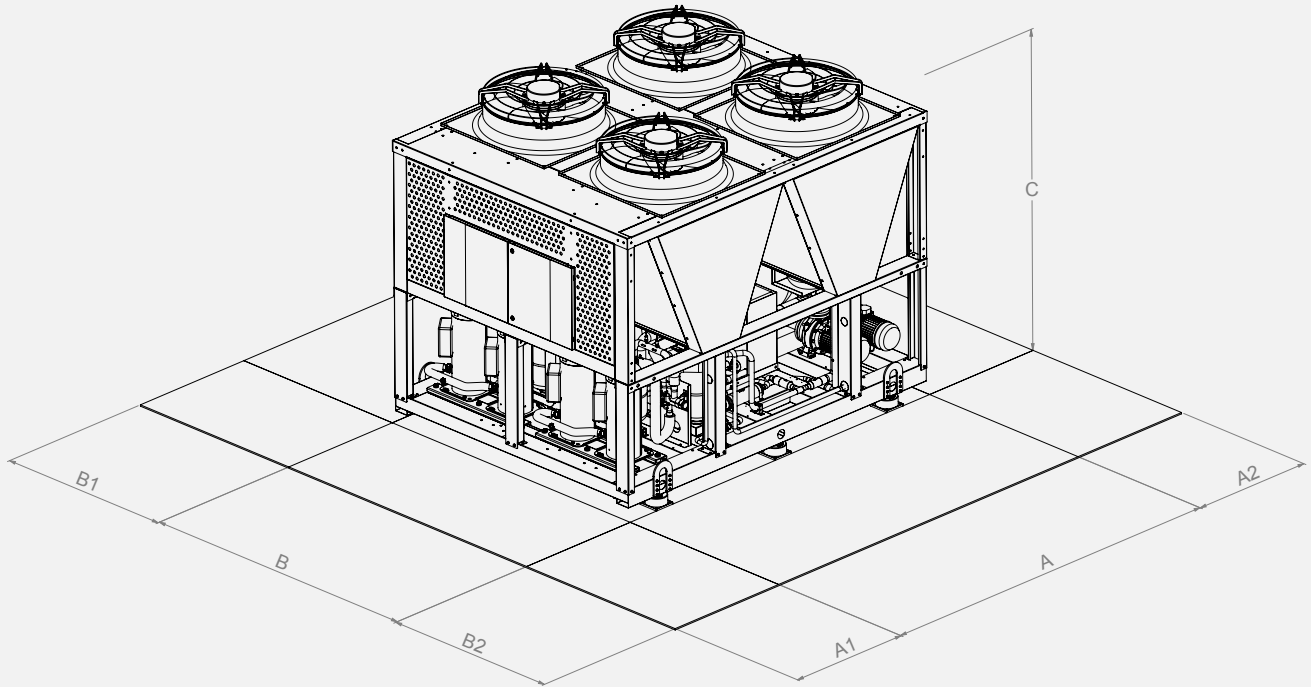

Model	Dimensions			Clearances				User heat exchanger	
	A [mm]	B [mm]	C [mm]	A1[mm]	A2 [mm]	B1 [mm]	B2 [mm]	Type	Ø *
02109	2860	1100	2350	1000	800	1000	1000	Victaulic	DN65 (2" 1/2)
02121	2860	1100	2350	1000	800	1000	1000	Victaulic	DN65 (2" 1/2)
02142	4060	1100	2350	1000	800	1000	1000	Victaulic	DN65 (2" 1/2)
02148	4060	1100	2350	1000	800	1000	1000	Victaulic	DN65 (2" 1/2)
02160	4060	1100	2350	1000	800	1000	1000	Victaulic	DN65 (2" 1/2)
04176	2860	2200	2350	1000	800	1000	1000	Victaulic	DN80 (3")
04199	2860	2200	2350	1000	800	1000	1000	Victaulic	DN80 (3")
04215	2860	2200	2350	1000	800	1000	1000	Victaulic	DN80 (3")
04237	2860	2200	2350	1000	800	1000	1000	Victaulic	DN80 (3")
04273	4060	2200	2350	1000	800	1000	1000	Victaulic	DN80 (3")
04304	4060	2200	2350	1000	800	1000	1000	Victaulic	DN80 (3")
04345	4060	2200	2350	1000	800	1000	1000	Victaulic	DN80 (3")

\* It depends on the hydronic version - refer to the technical bulletin

			02109	02121	02142	02148	02160	04176	
Cooling	Cooling capacity (1)	kW	103	113	132	138	148	165	
	Total absorbed power (1)	kW	33,8	38,9	41,3	44,4	49,8	52,6	
	EER (1)	W/W	3,05	2,90	3,19	3,11	2,97	3,14	
	Cooling capacity (2)	kW	139	151	177	188	202	224	
	Total absorbed power (2)	kW	36,5	42,7	44,1	47,7	53,0	55,7	
	EER (2)	W/W	3,81	3,53	4,01	3,94	3,82	4,01	
	SEER (5)	W/W	4,35	4,36	4,38	4,73	4,50	4,61	
	Cooling capacity (11)	kW	63,0	68,4	78,9	82,4	90,6	97,4	
	Total absorbed power (11)	kW	30,2	34,8	37,6	40,1	44,8	48,7	
	EER (11)	W/W	2,09	1,97	2,10	2,05	2,02	2,00	
	Water flow rate (1)	l/s	4,9	5,4	6,3	6,6	7,1	7,9	
Pressure drops in the heat exchanger, user side (1)	kPa	30,5	36,3	37,8	41,0	38,0	36,0		
Heating	Heating capacity (3)	kW	113	125	148	154	166	188	
	Total absorbed power (3)	kW	27,6	30,9	36,6	37,7	41,4	46,0	
	COP (3)	W/W	4,09	4,05	4,04	4,08	4,01	4,08	
	Heating capacity (4)	kW	108	120	142	148	160	179	
	Total absorbed power (4)	kW	32,9	37,5	43,9	45,3	49,4	55,9	
	COP (4)	W/W	3,30	3,20	3,22	3,26	3,23	3,21	
	SCOP (6)	W/W	3,72	3,77	3,62	3,69	3,68	3,90	
	Water flow rate (4)	l/s	5,2	5,7	6,8	7,1	7,6	8,6	
	Pressure drops in the heat exchanger, user side (4)	kPa	33,5	40,5	43,0	46,6	43,6	41,8	
Energy efficiency water 35°C/55°C	class	A+/A+	A+/A+	A+/A+	A+/A+	A+/A+	A++/A+		
Compressor	Compressor type		SCROLL						
	Refrigerant oil (type)		Emkarate RL 32 3MAF						
	No. of compressors	No.	2	2	2	2	2	2	
	Standard capacity steps	No.	2	3	2	3	3	4	
	Oil charge (Circuit 1)	l	4,44 + 4,44	4,44 + 4,44	4,44 + 4,44	6,3 + 4,44	6,3 + 4,44	3,25 + 3,25	
	Oil load (Circuit 2)	l	-	-	-	-	-	3,25 + 3,25	
	Refrigerant circuits	No.	1	1	1	1	1	2	
Refrigerant	Type		R410A						
	Refrigerant charge (Circuit 1) (7)	kg	26,5	27,0	34,5	42,0	40,0	22,0	
	Refrigerant charge (Circuit 2) (7)	kg	-	-	-	-	-	22,0	
	Tons of CO2 equivalent (7)	Ton	55,3	56,4	72,0	87,7	83,5	91,9	
	Design pressure (high/low)	bar	40,5/2,5	40,5/2,5	40,5/2,5	40,5/2,5	40,5/2,5	40,5/2,5	
Outdoor zone fans	Fan types		AXIAL						
	No. of fans	No.	2	2	3	3	3	4	
	Rated power (1)	kW	1,4	1,4	1,4	1,4	1,4	1,4	
	Maximum power	kW	3,80	3,80	5,70	5,70	5,70	7,60	
	Maximum absorbed current	A	3,9	3,9	3,9	3,9	3,9	3,9	
	Standard air flow rate	l/s	10021	9984	15109	15088	15045	20954	
Internal heat exchanger	Internal heat exchanger type		PHE – PLATE TYPE						
	No. of indoor heat exchangers	No.	1	1	1	1	1	1	
	Water content	l	6,87	6,87	7,88	7,88	8,89	11,40	
Hydraulic circuit	Max water-side pressure	bar	12	12	12	12	12	12	
	Max. hydraulic unit pressure (safety valve setting)	bar	6	6	6	6	6	6	
	Water connections		2" 1/2	2" 1/2	2" 1/2	2" 1/2	2" 1/2	3"	
	Minimum system water content (8)	l	490	630	630	820	820	480	
Sound data	Sound power (9)	dB (A)	88 std 87 SL 84 SSL	88 std 87 SL 84 SSL	88 std 87 SL 84 SSL	88 std 87 SL 84 SSL	88 std 87 SL 84 SSL	89 std 88 SL 85 SSL	
		Sound pressure (10)	dB (A)	56 std 55 SL 52 SSL	56 std 55 SL 52 SSL	55,9 std 54,9 SL 51,9 SSL	55,9 std 54,9 SL 51,9 SSL	55,9 std 54,9 SL 51,9 SSL	56,9 std 55,9 SL 52,9 SSL
	Power supply		400V/3P/50Hz						
Electrical data	Max. power input without accessories	kW	48,9	55,0	63,1	66,9	73,0	87,9	
	Max current absorbed without accessories	A	83,0	93,4	107,1	113,5	123,9	149,2	
	Maximum inrush current without accessories	A	285,6	332,3	346,0	358,1	368,5	289,2	
Dimensions and weights	A - Length	mm	2860	2860	4060	4060	4060	2860	
	B - Depth	mm	1100	1100	1100	1100	1100	2200	
	C - Height	mm	2350	2350	2350	2350	2350	2350	
	Net shipping weight	kg	1180	1210	1470	1530	1530	2030	
	Operating weight	kg	1190	1220	1480	1540	1540	2040	

(1) Cooling: outdoor air temperature 35°C; inlet/outlet water temperature 12/7°C.

(2) Cooling: outdoor air temperature 35°C; entering/leaving water temperature 23/18°C.

(3) Heating: outdoor air temperature 7°C d.b. 6°C w.b.; water inlet/outlet temp. 30/35°C.

(4) Heating: outdoor air temperature 7°C d.b. 6°C w.b.; water inlet/outlet temp. 40/45°C.

(5) Cooling: water inlet/outlet temperature 7/12°C.

(6) Heating: average climatic conditions; T<sub>biv</sub> = -7°C; inlet/outlet water temperature 30/35°C.

(7) Indicative data, subject to change. For the correct data, always refer to the technical nameplate on the unit.

(8) The indicated volume refers to the total required amount; the

designer must meet this requirement by taking into account the quantity already present inside the unit, depending on the selected hydronic kit (please check this value in the technical data sheet).

(9) Condition (1); value determined on the basis of measurements carried out in accordance with UNI EN ISO 9614-1

(10) Value calculated from the sound power level using ISO 3744:2010, referred to a distance of 10 m from the unit.

(11) Cooling BT version: outdoor air temperature 35°C, internal heat exchanger water temperature = -3/-8°C. Fluid treated with 35% ethylene glycol.

			04199	04215	04237	04273	04304	04345
Cooling	Cooling capacity (1)	kW	187	208	225	260	289	325
	Total absorbed power (1)	kW	59,4	67,2	77,5	80,6	92,9	112
	EER (1)	W/W	3,15	3,10	2,90	3,22	3,10	2,90
	Cooling capacity (2)	kW	252	282	301	351	388	434
	Total absorbed power (2)	kW	63,8	71,6	83,2	87,0	101	122
	EER (2)	W/W	3,95	3,94	3,62	4,04	3,86	3,56
	SEER (5)	W/W	4,64	4,71	4,53	4,65	4,73	4,42
	Cooling capacity (11)	kW	111	129	140	155	177	203
	Total absorbed power (11)	kW	54,3	60,0	69,4	72,3	84,2	99,9
	EER (11)	W/W	2,04	2,15	2,02	2,14	2,10	2,03
Water flow rate (1)	l/s	8,9	10,0	10,7	12,4	13,8	15,5	
Pressure drops in the heat exchanger, user side (1)	kPa	45,4	55,7	38,5	50,7	36,8	46,0	
Heating	Heating capacity (3)	kW	207	223	246	286	316	356
	Total absorbed power (3)	kW	50,7	54,8	61,1	69,2	78,3	88,5
	COP (3)	W/W	4,09	4,07	4,02	4,13	4,04	4,02
	Heating capacity (4)	kW	198	214	237	273	303	344
	Total absorbed power (4)	kW	61,5	66,0	74,0	83,8	94,7	108
	COP (4)	W/W	3,22	3,24	3,20	3,26	3,20	3,20
	SCOP (6)	W/W	3,84	3,96	4,00	3,92	3,95	4,01
	Water flow rate (4)	l/s	9,5	10,2	11,3	13,0	14,5	16,5
Pressure drops in the heat exchanger, user side (4)	kPa	50,6	58,6	42,5	55,8	40,4	51,6	
Energy efficiency water 35°C/55°C	class	A++/A+	A++/A+	A++/A+	A++/A+	A++/A+	A++/A+	
Compressor	Compressor type		SCROLL					
	Refrigerant oil (type)		Emkarate RL 32 3MAF					
	No. of compressors	No.	4	4	4	4	4	4
	Standard capacity steps	No.	6	4	6	5	5	5
	Oil charge (Circuit 1)	l	4,44 + 3,25	4,44 + 4,44	4,44 + 4,44	6,3 + 4,44	6,3 + 6,3	6,3 + 6,3
	Oil load (Circuit 2)	l	4,44 + 3,25	4,44 + 4,44	4,44 + 4,44	4,44 + 4,44	4,44 + 4,44	4,44 + 4,44
	Refrigerant circuits	No.	2	2	2	2	2	2
Refrigerant	Type		R410A					
	Refrigerant charge (Circuit 1) (7)	kg	18,0	25,5	28,5	43,0	47,0	50,0
	Refrigerant charge (Circuit 2) (7)	kg	18,0	24,0	28,5	36,0	34,0	30,0
	Tons of CO2 equivalent (7)	Ton	75,2	103,4	119,0	165,0	169,1	167,0
	Design pressure (high/low)	bar	40,5/2,5	40,5/2,5	40,5/2,5	40,5/2,5	40,5/2,5	40,5/2,5
Outdoor zone fans	Fan types		AXIAL					
	No. of fans	No.	4	4	4	6	6	6
	Rated power (1)	kW	1,4	1,4	1,4	1,4	1,4	1,4
	Maximum power	kW	7,60	7,60	7,60	11,40	11,40	11,40
	Maximum absorbed current	A	3,9	3,9	3,9	3,9	3,9	3,9
	Standard air flow rate	l/s	20888	20815	20738	31370	31264	31109
Internal heat exchanger	Internal heat exchanger type		PHE – PLATE TYPE					
	No. of indoor heat exchangers	No.	1	1	1	1	1	1
	Water content	l	11,40	11,40	15,50	15,50	22,10	22,10
Hydraulic circuit	Max water-side pressure	bar	12	12	12	12	12	12
	Max. hydraulic unit pressure (safety valve setting)	bar	6	6	6	6	6	6
	Water connections		3"	3"	3"	3"	3"	3"
	Minimum system water content (8)	l	610	610	780	1020	1020	1290
Sound data	Sound power (9)	dB (A)	89 std 88 SL 85 SSL	89 std 88 SL 85 SSL	90 std 89 SL 86 SSL	90 std 89 SL 86 SSL	91 std 90 SL 87 SSL	92 std 91 SL 88 SSL
	Sound pressure (10)	dB (A)	56,9 std 55,9 SL 52,9 SSL	56,9 std 55,9 SL 52,9 SSL	57,9 std 56,9 SL 53,9 SSL	57,8 std 56,9 SL 53,9 SSL	58,8 std/ 57,8 SL/ 54,8 SSL	59,8 std/ 58,8 SL/ 55,8 SSL
Electrical data	Power supply		400V/3P/50Hz					
	Max. power input without accessories	kW	92,8	97,8	110,0	123,8	139,8	160,1
	Max current absorbed without accessories	A	157,6	166,0	186,8	210,2	237,4	271,8
	Maximum inrush current without accessories	A	360,2	368,6	425,7	454,8	482,0	597,2
Dimensions and weights	A - Length	mm	2860	2860	2860	4060	4060	4060
	B - Depth	mm	2200	2200	2200	2200	2200	2200
	C - Height	mm	2350	2350	2350	2350	2350	2350
	Net shipping weight	kg	2060	2100	2130	2680	2880	2900
	Operating weight	kg	2070	2110	2140	2700	2900	2930

(1) Cooling: outdoor air temperature 35°C; inlet/outlet water temperature 12/7°C.

(2) Cooling: outdoor air temperature 35°C; entering/leaving water temperature 23/18°C.

(3) Heating: outdoor air temperature 7°C d.b. 6°C w.b.; water inlet/outlet temp. 30/35°C.

(4) Heating: outdoor air temperature 7°C d.b. 6°C w.b.; water inlet/outlet temp. 40/45°C.

(5) Cooling: water inlet/outlet temperature 7/12°C.

(6) Heating: average climatic conditions; T<sub>biv</sub> = -7°C; inlet/outlet water temperature 30/35°C.

(7) Indicative data, subject to change. For the correct data, always refer to the technical nameplate on the unit.

(8) The indicated volume refers to the total required amount; the designer must meet this

requirement by taking into account the quantity already present inside the unit, depending on the selected hydronic kit (please check this value in the technical data sheet).

(9) Condition (1); value determined on the basis of measurements carried out in accordance with UNI EN ISO 9614-1

(10) Value calculated from the sound power level using ISO 3744:2010, referred to a distance of 10 m from the unit.

(11) Cooling BT version: outdoor air temperature 35°C, internal heat exchanger water temperature = -3/-8°C. Fluid treated with 35% ethylene glycol.

## Price list

HWA1-A/H			02109	02121	02142	02148	02160	04176
HWA1-A/H	Reversible heat pump	£	43.593	46.217	54.504	55.616	59.176	73.709
<b>FACTORY-MOUNTED ACCESSORIES</b>								
2SFV	Double safety valve	£	415	415	415	415	831	831
ACK6	Summer-Winter Indication	£	207	207	207	207	207	207
BT	Reversible heat pump, BT version	£	4.280	4.280	5.408	6.761	7.872	4.240
C	Ductable version	£	3.374	3.374	5.450	5.450	5.450	5.450
CC	Condensation control down to -20°C (Only with EC fans)	£	2.076	2.076	2.855	2.855	2.855	3.633
C(S)	Ductable version with compressor soundproofing	£	4.361	4.466	6.614	6.614	6.963	7.086
CM	Serial communication module for Modbus	£	825	825	825	825	825	825
CT	Condensation control down to -10°C	£	379	379	379	379	561	561
DS	Partial heat recovery heat pump (desuperheater circuit)	£	3.155	3.485	4.943	5.766	4.979	7.914
EC	EC fan (included in C, BT, SSL versions). DC control included	£	2.076	2.076	2.855	2.855	2.855	3.633
GR1	Anti-intrusion kit for refrigeration circuit compartment	£	2.165	2.165	2.644	2.644	2.644	2.769
GR2	Anti-intrusion battery compartment kit	£	753	753	753	753	753	753
GR3	Anti-intrusion kit for battery compartment and circuit	£	2.918	2.918	3.396	3.396	3.396	3.521
IM	Magnetic circuit breakers on compressors and fans	£	844	844	844	844	1.480	1.713
KA1	Adhesive heater for heat exchanger + pump heater (if present). Not available for units with tank	£	246	246	246	246	246	246
KA2	Adhesive heater exchanger + pump heater (if present) + heater	£	909	909	909	909	909	909
KS	Lifting bracket kit	£	285	285	285	285	285	285
LQ	Internal electrical panel lights	£	454	454	454	454	454	454
PD	Twin pump, standard head	£	7.007	7.007	7.007	7.007	7.007	7.865
PD-SI	Dual standard-head pump + tank	£	10.245	10.245	11.614	11.614	11.614	11.809
PDAP	Dual high-head pump	£	8.046	8.046	8.046	9.343	9.603	9.603
PDAP-SI	Double high-head pump + tank	£	11.543	12.199	13.626	13.626	13.626	13.626
PS-SI	Standard head pump + tank	£	7.332	7.332	8.500	8.500	8.500	8.500
PS	Standard head pump	£	4.153	4.153	4.153	4.153	4.153	4.153
PSAP	High-head pump	£	4.802	4.802	4.802	6.034	6.034	6.034
PSAP-SI	High head pump + tank	£	8.371	8.371	9.538	9.538	9.538	9.538
RFM	Delivery and suction valves for compressors	£	410	410	818	818	818	818
SH	Schuko socket (with miniature circuit breaker)	£	272	272	272	272	272	272
SL	Silenced version	£	987	1.092	1.163	1.163	1.513	1.635
SS	Soft starter	£	3.715	4.955	4.955	4.955	5.353	5.353
SSL	Ultra-silent version	£	3.499	3.499	4.848	5.320	5.320	7.007
TE1	Special mechanical seal for glycol >40%	£	364	364	364	559	559	559
TR2	Cu/Al coil with Silver Line anti-corrosion treatment - Cu	£	3.374	3.763	4.412	4.931	4.931	5.190
<b>ACCESSORIES SUPPLIED SEPARATELY</b>								
AG	Rubber anti-vibration mounts	£	727	727	1.078	1.078	1.078	1.078
AM	Spring anti-vibration mounts	£	1.873	2.485	2.485	2.485	2.485	2.485
FY	Y-strainer	£	175	175	175	251	251	376
Hi-TV415	Touchscreen remote control	£	640	640	640	640	640	640
i-CR2	Wall-mounted remote control	£	319	319	319	319	319	319
RV	Starter kit consisting of 2 jaws and 2 plain stubs	£	150	150	150	150	150	150
SAS	Remote sensor	£	47	47	47	47	47	47

For accessories of the DAS monitoring system (ISK, LNC, OVPN), see chapter "Connection devices for Maxa DAS supervision system"

## Price list

HWA1-A/H			04199	04215	04237	04273	04304	04345
HWA1-A/H	Reversible heat pump	£	82.509	85.810	88.282	100.896	112.036	116.584
<b>FACTORY-MOUNTED ACCESSORIES</b>								
2SFV	Double safety valve	£	831	831	831	831	831	831
ACK6	Summer-Winter Indication	£	207	207	207	207	207	207
BT	Reversible heat pump, BT version	£	5.207	5.419	7.266	5.515	2.268	5.532
C	Ductable version	£	6.566	6.566	6.566	10.642	10.642	11.939
CC	Condensation control down to -20°C (Only with EC fans)	£	3.633	3.633	3.633	5.840	5.840	5.840
C(S)	Ductable version with compressor soundproofing	£	8.280	8.280	8.415	12.491	12.601	13.898
CM	Serial communication module for Modbus	£	825	825	825	825	825	825
CT	Condensation control down to -10°C	£	561	561	561	561	561	561
DS	Partial heat recovery heat pump (desuperheater circuit)	£	4.220	4.389	5.839	6.201	6.133	9.814
EC	EC fan (included in C, BT, SSL versions). DC control included	£	3.633	3.633	3.633	5.840	5.840	5.840
GR1	Anti-intrusion kit for refrigeration circuit compartment	£	2.769	2.769	2.769	3.247	3.247	3.247
GR2	Anti-intrusion battery compartment kit	£	1.070	1.070	1.362	1.362	1.622	1.622
GR3	Anti-intrusion kit for battery compartment and circuit	£	3.839	3.839	4.132	4.611	4.870	4.870
IM	Magnetic circuit breakers on compressors and fans	£	1.713	1.713	1.713	2.531	2.531	2.984
KA1	Adhesive heater for heat exchanger + pump heater (if present). Not available for units with tank	£	246	246	246	246	246	246
KA2	Adhesive resistance of heat exchanger + pump resistance (if present) + resistance	£	909	909	909	909	909	909
KS	Lifting bracket kit	£	285	285	285	285	285	285
LQ	Internal electrical panel lights	£	454	454	454	454	454	454
PD	Twin pump, standard head	£	7.865	8.383	8.383	9.811	10.252	11.160
PD-SI	Dual standard-head pump + tank	£	11.809	14.923	15.832	17.389	17.389	18.686
PDAP	Dual high-head pump	£	9.603	9.863	10.252	11.420	12.458	12.977
PDAP-SI	Double high-head pump + tank	£	11.160	11.420	11.939	12.977	13.366	13.366
PS	Standard head pump	£	4.153	4.153	4.153	5.710	6.436	6.436
PS-SI	Standard head pump + tank	£	10.382	10.382	10.900	11.939	12.329	12.329
PSAP	High-head pump	£	6.034	6.294	6.294	7.267	7.527	7.786
PSAP-SI	High head pump + tank	£	16.222	17.129	17.649	17.649	19.206	20.503
RFM	Delivery and suction valves for compressors	£	818	818	818	818	1.151	1.151
SH	Schuko socket (with miniature circuit breaker)	£	272	272	272	272	272	272
SL	Silenced version	£	1.713	1.713	1.849	1.849	1.960	1.960
SS	Soft starter	£	7.425	7.425	7.425	7.630	9.898	11.224
SSL	Ultra-silent version	£	8.306	8.954	9.084	13.236	13.756	13.756
TE1	Special mechanical seal for glycol >40%	£	559	559	559	559	559	559
TR2	Cu/Al coil with Silver Line anti-corrosion treatment - Cu	£	5.190	5.970	5.970	8.176	9.084	9.084
<b>ACCESSORIES SUPPLIED SEPARATELY</b>								
AG	Rubber anti-vibration mounts	£	1.315	1.315	1.315	1.315	2.257	2.457
AM	Spring anti-vibration mounts	£	2.444	2.444	2.444	2.444	3.169	3.169
FY	Y-strainer	£	376	426	426	426	477	477
Hi-TV415	Touchscreen remote control	£	640	640	640	640	640	640
i-CR2	Wall-mounted remote control	£	319	319	319	319	319	319
RV	Starter kit consisting of 2 jaws and 2 plain stubs	£	150	150	200	200	200	200
SAS	Remote sensor	£	47	47	47	47	47	47
<b>STANDARD</b>								
	Remote probe enablement	£					standard	
	Second setpoint enable	£					standard	

For accessories of the DAS monitoring system (ISK, LNC, OVPN), see chapter "Connection devices for Maxa DAS supervision system"



01271 850 204 | [energylabuk.com](http://energylabuk.com)  
sales@energylabuk.com | @the-energy-lab-solutions



April 2026

Registered Address: Millennium House, Brannam Crescent, Roundswell Business Park, Barnstaple, Devon, EX31 3TD United Kingdom | Company Number: 08586990

**MAXXA**<sup>®</sup>  
HEATING & COOLING

[www.maxa.it](http://www.maxa.it)



All the information and scripts contained in this catalogue are exclusive property of ADVANTIX SPA. ADVANTIX SPA might have patterns, brands, copyrights or other rights of intellectual property in being or outstanding and covering certain subjects or belonging to some products shown in this catalogue. The possession of this catalogue does not imply the right to use these patterns, brands, copyright or other intellectual properties unless it is allowed by ADVANTIX SPA with a written agreement. ADVANTIX SPA does not assume responsibility for any errors or imprecision in the content of this catalog and reserves the right to make changes to its products any time without notice, according for technical or commercial market needs.