

R290 GAS

i-290 Inverter Heat Pump Range

0106/0109/0112/0115/0118/0121/0123/0125/0127
0240/0250





i-290 Inverter Heat Pumps

Efficiency, Comfort and Environmental Sustainability

Solutions that maximize energy efficiency for heating, cooling, and domestic hot water production, ensuring a high level of environmental sustainability.

The use of **natural refrigerant R290** enables high performance with full respect for the environment, ensuring comfort and energy savings in residential, commercial and industrial applications.

The range is designed to adapt to diverse application contexts: **14 models** are available, with capacities from **6 to 50 kW**, offering versatility, reliability, and tailored performance.



78°C

Maximum water supply temperature up to 78°C, guaranteed on a continuous basis.



-20/+46°C

Perfect for any climate thanks to the wide operating range from -20°C to +46°C.



350 kW

Single units of 6 to 50 kW which, when configured in cascade, can reach a maximum of 350 kW.



A+++

Energy efficiency class up to A+++.

GWP = 0.02

R290 eco-friendly gas with very low climate impact, for sustainable applications.

Design

Unique design and modern aesthetics facilitate architectural integration in every context.

Made In Italy

Range conceived, designed and produced by Maxxa in the Arcole plant (Italy).

Easy Plug

All components have been arranged to facilitate the installation operations as much as possible.





Maximum respect for the environment

The **eco-friendly gas R290**, with an extremely low GWP of just 0.02 (Global Warming Potential), drastically reduces environmental impact compared to traditional gases, delivering a concrete improvement in environmental sustainability. This means that the environmental impact of R290 gas on global warming is very low.



Ease of Installation

The heat pumps in the i-290 range are designed for quick and straightforward commissioning. Thanks to the hydraulic connections located at the rear of the heat pump, where the electrical service terminal blocks are also positioned, installation and commissioning are significantly simplified.

Solution suitable for every system

The i-290 range can be perfectly and rapidly integrated both into new buildings and in combination with existing systems, allowing highly efficient operation with both radiant underfloor systems and traditional systems with high-temperature water. Numerous accessories and configurations make it possible to customize the equipment of each heat pump.

Reduced refrigerant charge

The i-290 heat pumps ensure a significantly reduced refrigerant charge compared to traditional R32 solutions. For the same heating capacity, the amount of R290 required is considerably lower, with values that remain limited even in the higher-capacity models.

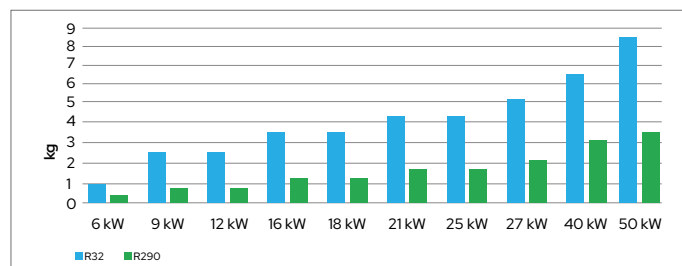

High level of safety

The i-290 heat pumps guarantee high safety standards. In sizes from O106 to O127, the use of **antispark components** always ensures safe operation of the heat pump. In the larger sizes, O240 and O250, the use of **leak detection sensors**, installed directly inside the heat pumps, determines their overall safety.

The i-290 heat pumps up to size O127 are also equipped as standard with a **air separator** that continuously removes any air and gas present in the hydraulic circuit.

The internal filter creates turbulence, promoting the separation of micro-bubbles, which are then automatically expelled by a float valve. This component improves efficiency, reduces noise and extends the service life of the system.



Assured performance all year round

The indispensable comfort ensured by domestic water systems, and the resulting increase in demand for domestic hot water, are perfectly met by i-290 technology, which confirms and extends the application range of heat pumps designed for this purpose. The i-290 range makes it possible to produce technical hot water under any outdoor temperature condition, from +46°C down to -20°C.

i-290 0106-0118



Monobloc inverter air-to-water reversible heat pump with R290

6 kW-18 kW

The latest evolution of MAXA's full inverter heat pump technology uses the eco-friendly refrigerant gas R290. This new evolutionary step further simplifies the design of systems fully managed by the heat pump alone. In fact, thanks to the 75°C maximum water temperature achievable with the i-290 range, application on systems requiring high supply temperatures is also very straightforward. Finally, the direct replacement of existing systems that previously operated with combustion appliances is very manageable.



Construction Features

- Proprietary control system with microcontroller-based regulation, superheat control logic via electronic expansion valve.
- Compressor: Twin Rotary DC inverter.
- Fans: axial type with brushless DC motor.
- Source heat exchanger: finned coil with copper tubes and aluminum fins with hydrophilic coating.
- User plate heat exchanger with AISI 304 stainless steel brazed plates, featuring low pressure drop on the water side.
- Refrigerant circuit made of copper tubing, including: condensing pressure control, electronic thermostatic valve, reversing valve, high-pressure switch, liquid separator, pressure tapping point, bidirectional metal mesh filters, high- and low-pressure transducers.
- Integrated hydraulic circuit with high-efficiency variable-speed brushless circulator, flow meter, deaerator with air vent valve, 3-bar overpressure valve, and system filling and drain cock.
- The SL version ensures reduced sound emissions, particularly with regard to standard EN12102-1:2022. The reduction of the sound power level under A7/W55 conditions is between 2 and 4 dB(A).

Logics and Controls:

- All units can operate in three different modes: heating, cooling, and domestic hot water, with specific programs that maximize performance in all conditions, including optional control via climatic compensation curve.
- The i-290 series units are capable of managing mixing valves, diverting valves and secondary-side circulation pumps; they are also able to control the solar thermal system, any integration with external heat sources, and integration with external Home/Building Automation or Home Automation systems.
- ModBus RTU available as standard.
- All units in the i-290 series (0106/0118) are supplied as standard with the e-Pro wired controller, providing complete control of the heat pump both locally and remotely via connectivity, once connected to the Wi-Fi network.
- Thanks to the MyMaxa app, you can associate one or more MAXA heat pump installations with your user profile and thus obtain full remote control of them.

Operating Areas

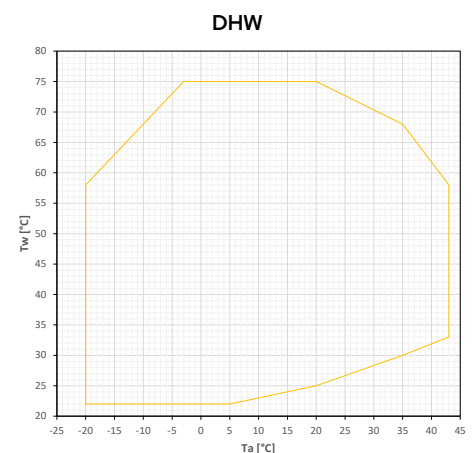
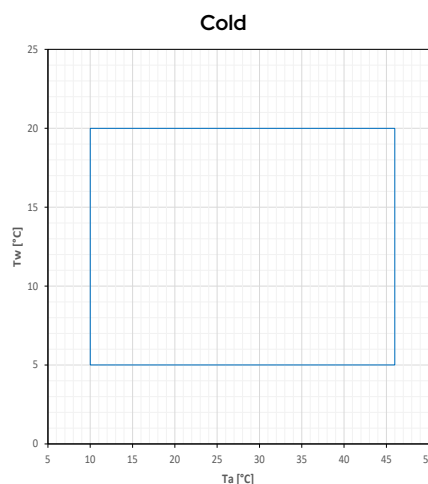
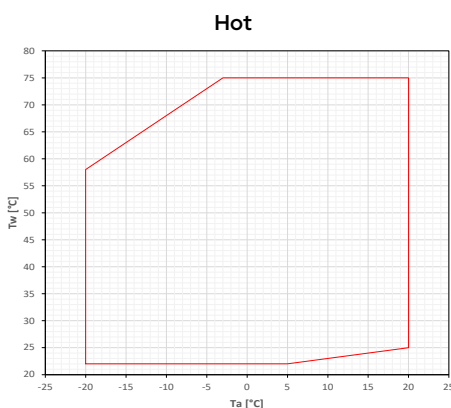

Tw: water temperature - Ta: outdoor air temperature

Accessories

Factory-installed

- **KA** - Antifreeze kit (heat exchanger + base) – includes the use of a self-heating cable that is glued to the base of the unit near the condenser coil, and a PET heater positioned on the plate heat exchanger face.
- **KA3** - Antifreeze kit (base only) - provides exclusively for the use of a self-heating cable that is applied to the base of the unit near the condensing coil.
- **TR2** - Anti-corrosion treatment for coils – thanks to the treatment, the coil becomes flexible to withstand thermal expansion and contraction, mechanically resistant, protected against UV rays and dirt-repellent. Heat transfer losses are very limited. The treatment ensures coil protection in virtually all environmental conditions: from coastal to rural areas, from industrial to urban zones. The treatment withstands 6000 h according to ASTM B117.
- **TR2C4** - Anti-corrosion treatment on coil and sheet metal – includes a TR2-type treatment on the coil and, in addition, the hot-dip galvanized steel panels are painted so as to make them suitable for unit installation in C4H environments, in accordance with UNI EN 12944. The external fastening hardware is made of AISI 304 material, class A2. The treatment also includes the fan protection grille, while the galvanized sheets inside the unit (electrical panel casing and inductances) are excluded.
- **RP** - Coil protective grilles – wire mesh to prevent foreign objects from entering the coil and to protect the coil from accidental contact with objects or people.

Provided separately

- **SAS** - Domestic hot water probe / Remote system probe – in some system configurations (e.g. heat pump in parallel with the boiler on the same hydronic circuit and diverter valve for boiler exclusion), it may be necessary to enable a system temperature probe so that the unit controller can correctly manage the operation. The remote system probe controls the heat pump temperature only during the compressor start-up phase; shutdown is managed by the probe located on the heat pump flow line.
- **SPS** - Solar panel probe for GI3 – probe required to measure the temperature of the solar panels when the unit is integrated with a solar thermal system.
- **AG** - Anti-vibration kit – designed to prevent transmission of vibrations to the structure; must be installed under the unit, in the dedicated mounting holes.
- **VRC** - Condensate drip tray – galvanized sheet metal container to be installed at the base of the unit for collecting condensate water.
- **FY** - Y-strainer – contains a stainless steel mesh screen (500 µm filtration) that collects solid materials present in the water. Filtration prevents blockage and/or damage to the devices installed downstream of the strainer. Alternatively, it is possible to install a dirt separator that ensures a filtration level not greater than 1 mm (in this case, it is no longer necessary to install the Y-strainer).
- **FD** - Dirt separator – allows the heavier impurities present in the hydraulic circuit to be stopped and retained, as they are captured by a synthetic filter mesh and collected in a settling chamber. A magnetic device located inside the body of the dirt separator also makes it possible to trap ferromagnetic particles.
- **VDIS2** - Diverting valve – 3-way motorized ball valve DN (1"1/4) Kvs 19.2, 1" ½ MMM connections, complete with actuator.
- **ACT** - Technical storage tank (see dedicated section).
- **VSA** - Anti-freeze thermal discharge valve – a valve capable of opening at 0°C to prevent ice formation inside the pipes.
- **RP** - Coil protection grilles – wire mesh to prevent foreign objects from entering the coil and to protect the coil from accidental contact with objects or people (supplied as a separate accessory and to be installed by the installer).
- **e-LITE**** - Color touch-screen wired controller, which can be used as a remote keypad for the heat pump, as it replicates the functions of the on-board unit display. It is equipped with local temperature sensing and time scheduling.
- **Hi-TV415**** - Color touchscreen wired remote controller for centralized management of a chiller/heat pump cascade, for up to 7 units.
- **Connect Box**** - Wi-Fi communication gateway for the Maxa Connect App.
- **GI3**** - External system management module - enables management of the following functions: recirculation pump control, plant-side mixing valve control, solar thermal integration control.
- **ISK**** - USB/RS485 serial converter – interface device capable of reading and writing control registers via the RS485 standard and converting them to a USB port that can be connected to any supervision system.
- **LNC**** - LAN-Wi-Fi router – device that allows the unit to be connected to a local network via Ethernet cable or Wi-Fi coverage for remote monitoring.
- **OVPN**** - 3G LAN-Wi-Fi router with VPN tunnel – device that allows the unit to be connected remotely with an industrial router using the secure OPENVPN service.

** Accessories not usable simultaneously



e-PRO
Wi-Fi multifunction remote controller
STANDARD



e-LITE
Multifunction remote controller
ACCESSORY



Hi-TV415
Touch screen remote controller for cascade management (max 7 units)
ACCESSORY

			0106	0109	0109 T **	0112
Cooling	Cooling capacity (1)	kW	5,43	8,57	8,57	10,7
	Power input (1)	kW	1,95	2,77	2,77	3,75
	EER (1)	W/W	2,79	3,09	3,09	2,85
	Cooling capacity (2)	kW	5,62	9,15	9,15	12,6
	Power input (2)	kW	1,25	1,93	1,93	2,83
	EER (2)	W/W	4,48	4,75	4,75	4,44
	SEER (5)	W/W	4,77	5,41	5,41	4,72
	Water flow rate (1)	L/s	0,26	0,40	0,40	0,49
	Pressure drops in the heat exchanger on the user side (1)	kPa	7,8	5,1	5,1	7,5
Nominal available head (1)	kPa	65,7	57,3	57,3	81,2	
Heating	Heating capacity (3)	kW	6,24	9,07	9,07	12,6
	Input power (3)	kW	1,31	1,99	1,99	2,61
	COP (3)	W/W	4,76	4,56	4,56	4,83
	Heating capacity (4)	kW	5,97	8,74	8,74	11,6
	Power input (4)	kW	1,91	2,85	2,85	3,60
	COP (4)	W/W	3,12	3,07	3,07	3,22
	Heating capacity (12)	kW	4,50	7,93	7,93	8,52
	Power input (12)	kW	1,61	2,66	2,66	3,01
	COP (12)	W/W	2,81	2,98	2,98	2,84
	Heating capacity (11)	kW	5,87	9,05	9,05	12,0
	Power input (11)	kW	2,29	3,40	3,40	4,60
	COP (11)	W/W	2,57	2,66	2,66	2,62
	SCOP (6)	W/W	4,74	5,07	5,07	4,71
	Water flow rate (3)	L/s	0,29	0,44	0,44	0,58
	Pressure drops in the user-side heat exchanger (3)	kPa	9,6	6,2	6,2	10,5
	Nominal useful head (3)	kPa	63,6	53,0	53,0	79,5
	Energy efficiency water 35°C / 55°C	Class	A+++/A++	A+++/A+++	A+++/A+++	A+++/A++
Compressor	Type		Twin Rotary DC Inverter			
	Refrigerant oil (type)	A	PZ46M	PZ46M	PZ46M	PZ46M
	Number of compressors	no.	1	1	1	1
	Oil charge (quantity)	L	0,45	0,52	0,52	0,90
Refrigerant	Type		R290			
	Refrigerant charge (7)	kg	0,43	0,75	0,75	1,00
	Refrigerant quantity in tonnes of CO ₂ equivalent (7)	Ton	0,000009	0,000015	0,000015	0,000020
	Design pressure (high/low) heat pump mode	bar	30,3/0,3	30,3/0,3	30,3/0,3	30,3/0,3
Outdoor zone fans	Design pressure (high/low) chiller mode	bar	30,3/2	30,3/2	30,3/2	30,3/2
	Type		Brushless DC Motor			
Internal heat exchanger	Number	no.	1	1	1	2
	Internal heat exchanger type		Plate type			
	No. of indoor heat exchangers	no.	1	1	1	1
Hydraulic circuit	Water content	L	0,94	1,69	1,69	1,69
	Water content of the hydronic circuit	L	2,2	2,2	2,2	3,7
	Maximum water-side pressure	bar	3	3	3	3
	Hydraulic connections	inch	G1"	G1"	G1"	G1"
	Minimum water volume (8)	L	65	95	95	125
	Maximum circulator power	kW	0,095	0,095	0,095	0,14
Sound data	Maximum absorbed current of circulator	A	0,7	0,7	0,7	1,2
	Sound power level L _w (9)	dB(A)	57	57	57	59
	Sound pressure at 1 m distance L _{p1} (10)	dB(A)	42	43	43	44
Sound data SL version	Sound pressure at 10 m distance L _{p10} (10)	dB(A)	26	27	27	28
	Sound power level L _w (9)	dB(A)	55	55	55	57
	Sound pressure at 1 m distance L _{p1} (10)	dB(A)	40	40	40	42
Electrical data	Sound pressure at 10 m distance L _{p10} (10)	dB(A)	24	26	26	26
	Power supply		230V/1/50Hz		400V/3/50Hz	230V/1/50Hz
	Maximum absorbed power	kW	2,9	4,4	4,4	5,1
	Maximum absorbed current	A	14,4	21,4	6,7	25,8
	Maximum power input with antifreeze kit	kW	3,0	4,6	4,6	5,3
	Maximum current draw with antifreeze kit	A	15,0	22,0	7,3	26,4

(1) Cooling: outdoor air temperature 35 °C; inlet/outlet water temperature 12/7 °C.

(2) Cooling: outdoor air temperature 35 °C; inlet/outlet water temperature 23/18 °C.

(3) Heating: outdoor air temperature 7 °C d.b. 6 °C w.b.; inlet/outlet water temperature 30/35 °C.

(4) Heating: outdoor air temperature 7 °C d.b. 6 °C w.b.; water inlet/outlet temp. 47/55 °C.

(5) Cooling: low temperature, variable output, constant flow rate.

(6) Heating: average climate conditions; T_{biv} = -7 °C; low temperature, variable output, constant flow rate.

(7) Indicative data, subject to change. For the correct data, always refer to the technical nameplate on the unit.

(8) Calculated for a 10 °C decrease in system water temperature with a defrost cycle lasting 6

minutes.

(9) Sound power: heating mode according to EN 12102:2022 Annex A; value determined on the basis of measurements carried out in accordance with UNI EN ISO 9614-1, in compliance with Eurovent certification requirements.

(10) Sound pressure: value calculated from the sound power level in condition (9) using standard UNI EN ISO 3744:2010.

(11) Heating: outdoor air temperature 7 °C d.b. 6 °C w.b.; inlet/outlet water temperature 55/65 °C.

(12) Heating: outdoor air temperature -7 °C d.b. -8 °C w.b.; water inlet/outlet temp. 30/35 °C.

** Preliminary data. Available from: summer 2026

			0112 T **	0114 **	0115	0118
Cooling	Cooling capacity (1)	kW	10,7	11,60	12,4	13,8
	Power input (1)	kW	3,92	3,60	3,71	4,34
	EER (1)	W/W	2,73	3,22	3,35	3,16
	Cooling capacity (2)	kW	12,2	11,7	12,9	13,9
	Power input (2)	kW	2,93	2,40	2,40	2,69
	EER (2)	W/W	4,16	4,88	5,37	5,18
	SEER (5)	W/W	4,56	4,93	5,02	5,04
	Water flow rate (1)	L/s	0,49	0,55	0,57	0,66
	Pressure drops in the heat exchanger on the user side (1)	kPa	7,5	10,6	11,7	16,0
Nominal available head (1)	kPa	81,2	85,0	79,7	73,5	
Heating	Heating capacity (3)	kW	12,3	14,8	16,3	18,7
	Input power (3)	kW	2,67	3,06	3,30	4,05
	COP (3)	W/W	4,61	4,84	4,94	4,62
	Heating capacity (4)	kW	11,3	13,7	15,2	17,4
	Power input (4)	kW	3,70	5,10	4,52	5,32
	COP (4)	W/W	3,05	3,17	3,37	3,27
	Heating capacity (12)	kW	8,68	10,7	12,94	12,56
	Power input (12)	kW	3,02	3,49	4,44	4,38
	COP (12)	W/W	2,87	3,07	2,91	2,88
	Heating capacity (11)	kW	12,3	13,3	14,7	16,7
	Power input (11)	kW	4,75	5,10	5,17	6,04
	COP (11)	W/W	2,59	2,58	2,83	2,76
	SCOP (6)	W/W	4,63	4,91	4,85	4,76
	Water flow rate (3)	L/s	0,58	0,71	0,78	0,87
	Pressure drops in the user-side heat exchanger (3)	kPa	10,5	17,4	22,0	27,8
	Nominal useful head (3)	kPa	79,5	77,2	66,8	59,8
	Energy efficiency water 35°C / 55°C	Class	A+++/A++	A+++/A++	A+++/A++	A+++/A++
Compressor	Type		Twin Rotary DC Inverter			
	Refrigerant oil (type)	A	VG60	VG60	PZ46M	PZ46M
	Number of compressors	no.	1	1	1	1
	Oil charge (quantity)	L	0,9	0,9	0,9	0,9
Refrigerant	Type		R290			
	Refrigerant charge (7)	kg	1,00	1,27	1,27	1,27
	Refrigerant quantity in tonnes of CO ₂ equivalent (7)	Ton	0,000020	0,000025	0,000025	0,000025
	Design pressure (high/low) heat pump mode	bar	30,3/0,3	30,3/0,3	30,3/0,3	30,3/0,3
Design pressure (high/low) chiller mode	bar	30,3/2	30,3/2	30,3/2	30,3/2	
Outdoor zone fans	Type		Brushless DC Motor			
	Number	no.	2	2	2	2
Internal heat exchanger	Internal heat exchanger type		Plate type			
	No. of indoor heat exchangers	no.	1	1	1	1
	Water content	L	1,69	1,69	1,69	1,69
Hydraulic circuit	Water content of the hydronic circuit	L	3,7	3,7	3,7	3,7
	Maximum water-side pressure	bar	3	3	3	3
	Hydraulic connections	inch	G1"	G1"	G1"	G1"
	Minimum water volume (8)	L	125	155	155	155
	Maximum circulator power	kW	0,14	0,14	0,14	0,14
	Maximum absorbed current of circulator	A	1,2	1,2	1,2	1,2
Sound data	Sound power level L _w (9)	dB(A)	59	62	62	62
	Sound pressure at 1 m distance L _{p1} (10)	dB(A)	44	47	47	47
	Sound pressure at 10 m distance L _{p10} (10)	dB(A)	28	31	31	31
Sound data SL version	Sound power level L _w (9)	dB(A)	57	57	57	57
	Sound pressure at 1 m distance L _{p1} (10)	dB(A)	42	42	42	42
	Sound pressure at 10 m distance L _{p10} (10)	dB(A)	26	26	26	26
Electrical data	Power supply		400V/3/50Hz	230V/1/50Hz	400V/3/50Hz	
	Maximum absorbed power	kW	5,2	6,4	7,7	8,2
	Maximum absorbed current	A	9,5	28,5	15,8	16,5
	Maximum power input with antifreeze kit	kW	5,3	6,5	7,9	8,3
	Maximum current draw with antifreeze kit	A	10,1	29,1	16,4	17,1

(1) Cooling: outdoor air temperature 35 °C; inlet/outlet water temperature 12/7 °C.

(2) Cooling: outdoor air temperature 35 °C; inlet/outlet water temperature 23/18 °C.

(3) Heating: outdoor air temperature 7 °C d.b. 6 °C w.b.; inlet/outlet water temperature 30/35 °C.

(4) Heating: outdoor air temperature 7 °C d.b. 6 °C w.b.; water inlet/outlet temp. 47/55 °C.

(5) Cooling: low temperature, variable output, constant flow rate.

(6) Heating: average climate conditions; T_{biv} = -7 °C; low temperature, variable output, constant flow rate.

(7) Indicative data, subject to change. For the correct data, always refer to the technical nameplate on the unit.

(8) Calculated for a 10 °C decrease in system water temperature with a defrost cycle lasting 6

minutes.

(9) Sound power: heating mode according to EN 12102:2022 Annex A; value determined on the basis of measurements carried out in accordance with UNI EN ISO 9614-1, in compliance with Eurovent certification requirements.

(10) Sound pressure: value calculated from the sound power level in condition (9) using standard UNI EN ISO 3744:2010.

(11) Heating: outdoor air temperature 7 °C d.b. 6 °C w.b.; inlet/outlet water temperature 55/65 °C.

(12) Heating: outdoor air temperature -7 °C d.b. -8 °C w.b.; water inlet/outlet temp. 30/35 °C.

** Preliminary data. Available from: summer 2026

Dimensional Drawings

i-290 0106 / 0109 / 0109 T

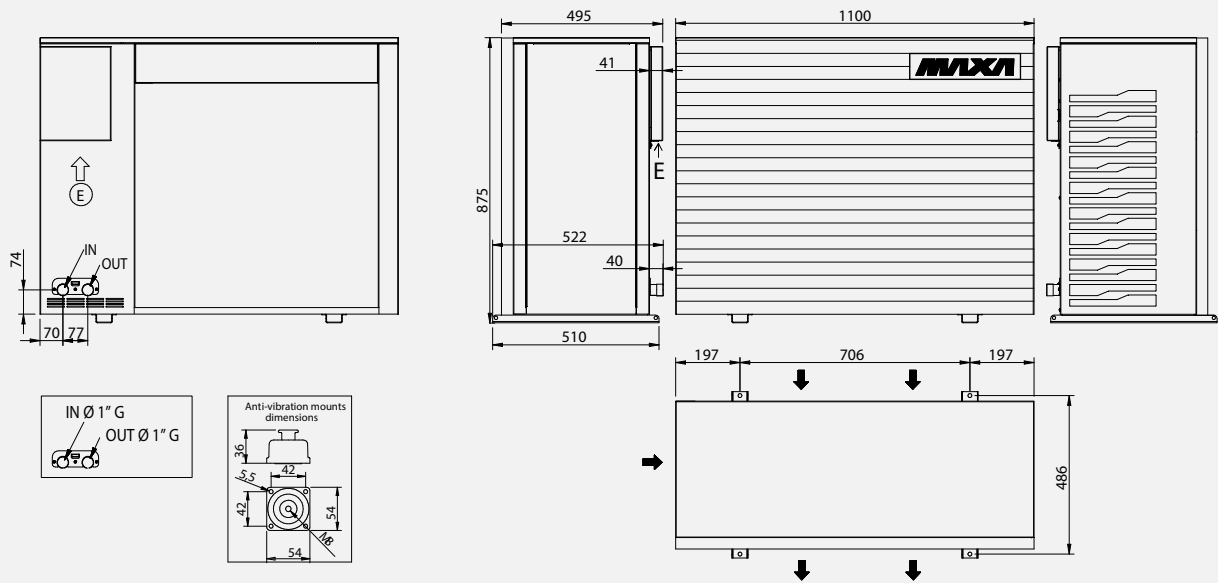

i-290 0112 / 0112 T / 0114 / 0115 / 0118

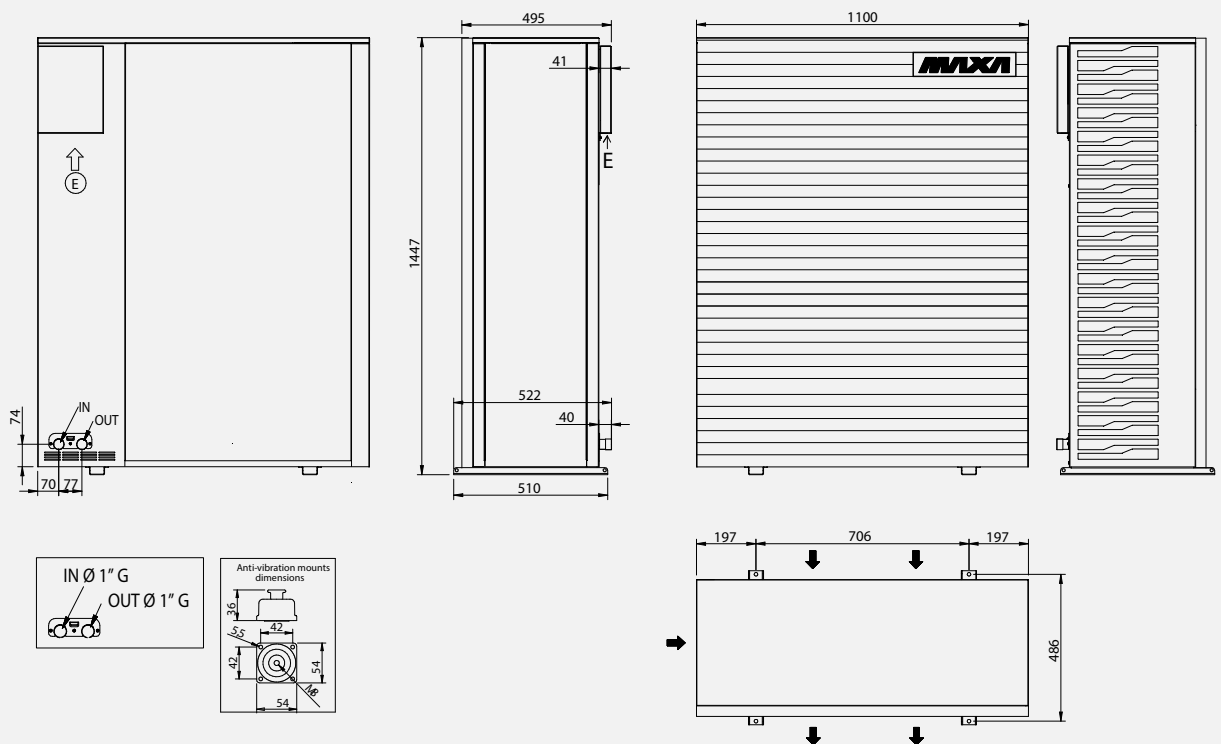

		0106	0109	0109 T	0112	0112 T	0114	0115	0118
L	mm	1105	1105	1105	1105	1105	1105	1105	1105
D	mm	512	512	512	512	512	512	512	512
H	mm	870	870	870	1440	1440	1440	1440	1440
Shipping weight	Kg	117	119	129	170	179	184	188	188

E: Power supply input

Dimensions in mm

System Diagram - Standard Application

1	i-290 heat pump	7	Expansion vessel	15	Y-strainer / Dirt separator filter (FD)	22	Mixed circuit pump (zone 2)
2	3-way DHW/system valve (VDIS)	10	Water connection	19	Degasser	22 ^{bis}	Direct circuit pump (zone 1)
3	DHW electric heater	11	Local thermostat (zone 1)	20	Mixing valve	24	Technical water tank (Puffroller)
4	DHW temperature sensor (SAS)	11 ^{bis}	Local thermostat (zone 2)	21	Mixed circuit water sensor	30	GI3 - External extension module
5	DHW Tank (Caddy)	13	e-PRO control				

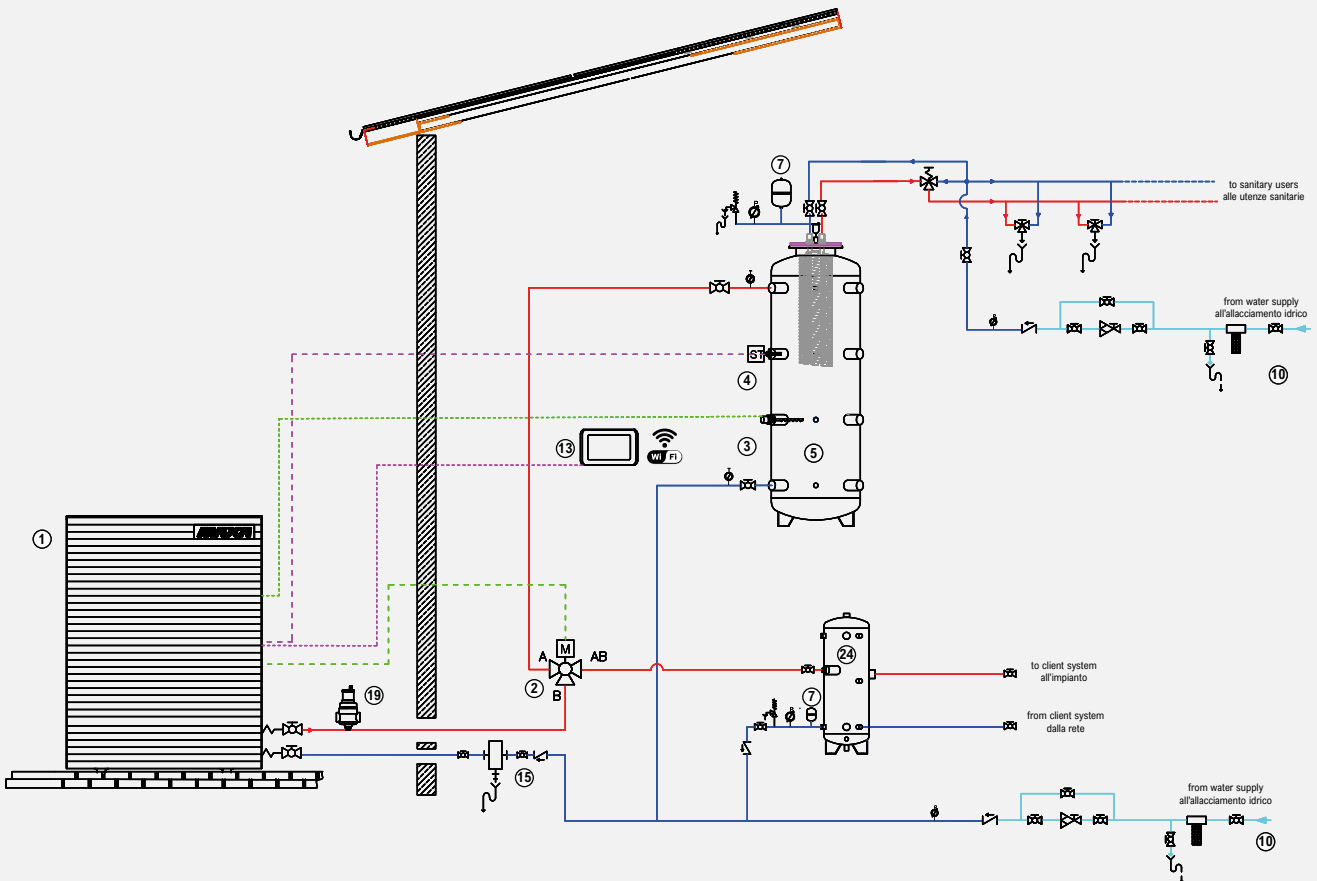
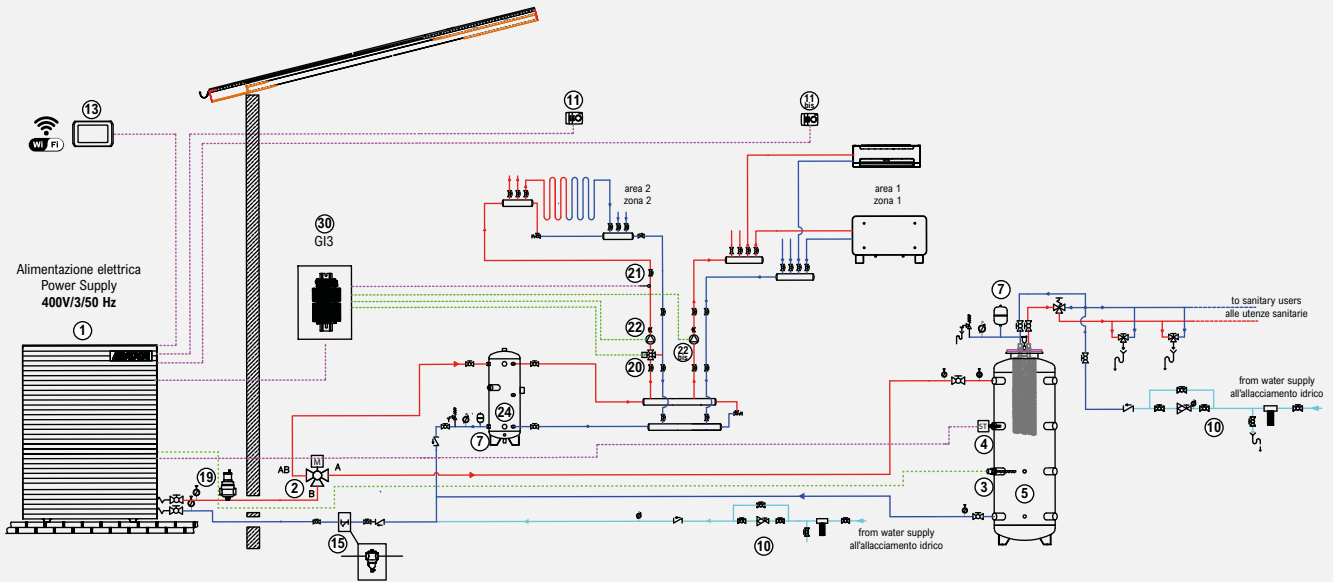

Purely indicative and non-binding diagram; for the construction of the system, it is necessary to refer to a design prepared by a qualified technician.

Price list

		i-290	i-290 SL
0106	code	011242220350000D01	011242260350000D01
	£	6.691 *	7.211 *
0109	code	011242220360000D01	011242260360000D01
	£	7.242 *	7.762 *
0109 T	code	Contact our office	
	£	Contact our office	
0112	code	011242220370000D01	011242260370000D01
	£	9.247 *	9.767 *
0112 T	code	Contact our office	
	£	Contact our office	
0114	code	Contact our office	
	£	Contact our office	
0115	code	011242221380000D01	011242261380000D01
	£	10.296 *	10.816 *
0118	code	011242221390000D01	011242261390000D01
	£	10.878 *	11.398 *

i-290			0106	0109	0109 T	0112	0112 T	0114	0115	0118
FACTORY-MOUNTED ACCESSORIES										
CM	Serial communication module for Modbus	£	Standard							
KA	Anti-freeze kit (heat exchanger + base)	£	387	387	387	387	387	387	387	387
KA3	Adhesive base heater	£	240	240	240	240	240	240	240	240
RP	Battery protection nets	£	220	220	220	270	270	270	270	270
TR2	Cu/Al coil with anti-corrosion treatment	£	1.180	1.370	1.370	1.460	1.460	1.650	1.650	1.650
TR2C4	Cu/Al coil and sheet metal with anti-corrosion treatment	£	1.760	1.950	1.950	2.040	2.040	2.230	2.230	2.230
ACCESSORIES SUPPLIED SEPARATELY										
e-PRO*	Wired Remote control, Wi-Fi connected	code	010022520010							
		£	450							
e-LITE*	Multifunction touch screen wired control	code	0110490101							
		£	450							
Hi-TV415*	Centralized multifunction touch screen remote control	code	010312300001							
		£	640							
Connect Box **	Heat pump communication gateway and MAXA CONNECT	code	0110490103							
		£	309							
VSA	Anti-freeze thermal discharge valve	code	010112532500010							
		£	390							
GI3 **	Hardware expansion module	code	01821000001							
		£	860							
AG	Anti-vibration support	code	015908010045							
		£	170							
RP	Battery protection nets	code	01030232001				01030232101			
		£	220				270			
FD	Dirt separator filter	code	0119100075				0119100076			
		£	115				272			
FY	Y-strainer	code	0171212401							
		£	89							
SAS	DHW storage probe - Remote probe	code	0110321000001							
		£	47							
SPS	Solar panel sensor	code	CH-CC-EN-ST-0015							
		£	101							
VDIS2	Three-way diverting valve for domestic hot water production in a thermal storage tank	code	0110490077							
		£	399							

* Remote control connected and degasser included

* Accessories that cannot be used simultaneously

** Accessories not usable simultaneously

i-290 0121-0127

Monobloc inverter air-to-water reversible heat pump with R290

21 kW–27 kW



Range of heat pumps from 21 to 27 kW, equipped with eco-friendly R290 refrigerant gas, representing the most advanced evolution of full inverter technology.

The 21 to 27 kW range is able to reach a maximum water temperature of 78°C; this feature allows it to be combined with a wide variety of heating systems. Ideal for replacing combustion-based systems, it ensures simple installation and optimal energy efficiency, with a reduced environmental impact.



Construction Features

- Proprietary control system with microcontroller-based regulation, superheat control logic via electronic expansion valve.
- Compressors: DC inverter scroll.
- Fans: axial type with brushless DC motor.
- Source heat exchanger: optimized with a finned coil circuit, copper tubes and aluminum fins.
- User plate heat exchanger with AISI 304 stainless steel brazed plates, featuring low pressure drop on the water side.
- Refrigerant circuit made of copper tubing, including: condensation control, electronic thermostatic valve, reversing valve, high-pressure switch, liquid separator, liquid receiver, pressure tapping point, unidirectional filter-drier, high- and low-pressure transducers.
- Integrated hydraulic circuit with high-efficiency variable-speed brushless circulator, flow meter, deaerator with air vent valve, 6 bar overpressure valve, and system filling and drain cock.

Logics and Controls:

- All units can operate in three different modes: heating, cooling, and domestic hot water, with specific programs that maximize performance in all conditions, including optional control via climatic compensation curve.
- The i-290 series units are capable of managing mixing valves, diverting valves and secondary-side circulation pumps; they are also able to control the solar thermal system, any integration with external heat sources, and integration with external Home/Building Automation or Home Automation systems.
- ModBus RTU available as "CM" accessory.
- All units in the i-290 (0121/0127) series are equipped as standard with the e-Pro wired controller, providing full control of the heat pump both locally and remotely via connectivity, once connected to the Wi-Fi network.
- Thanks to the MyMaxa app, you can associate one or more MAXA heat pump installations with your user profile and thus obtain full remote control of them.

Operating Areas

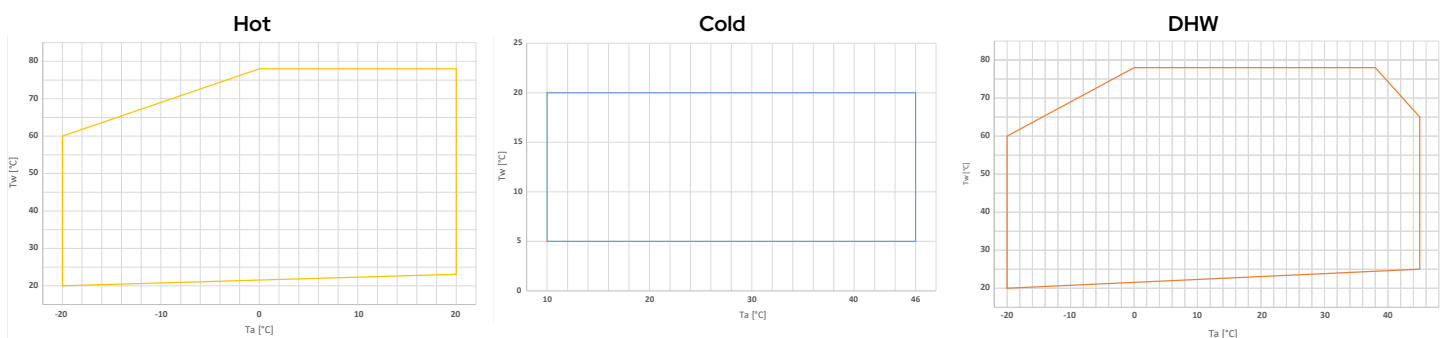

Tw: water temperature - Ta: outdoor air temperature

Accessories

Factory-installed

- **KA *** - Anti-freeze kit (heat exchanger + base) – uses a self-heating cable that is bonded to the base of the unit near the condensing coil, and a PET heater positioned on the plate heat exchanger face.
- **KA3 *** - Anti-freeze kit (base only) – provides exclusively for the use of a self-heating cable applied to the base of the unit near the condenser coil.
- **TR2** - Anti-corrosion treatment for coils – thanks to the treatment, the coil becomes flexible to withstand thermal contractions and expansions, mechanically resistant, protected against UV rays and repellent to dirt. Heat transfer losses are very limited. The treatment guarantees protection of the coils under virtually all environmental conditions: from coastal to rural areas, from industrial to urban zones. The treatment withstands 6000 h in accordance with ASTM B117.
- **TR2C4** - Anti-corrosion treatment on coil and sheet metal – includes a TR2-type treatment of the coil and, in addition, the hot-dip galvanized steel panels are painted to make them suitable for unit installation in C4H environments, in accordance with UNI EN 12944. The external fastening hardware is made of AISI 304, class A2. The treatment also includes the fan protection grille, while the galvanized sheet metal inside the unit (electrical panel casing and inductors) is excluded.
- **RP** - Coil protective grilles – wire mesh to prevent foreign objects from entering the coil and to protect the coil from accidental contact with objects or people.
- **CM** - BMS connectivity setup – ModBus protocol included – accessory that enables the connection of the unit to external controllers via serial cable with RS-485 electrical standard and ModBus RTU protocol.
- **SSL** - thanks to the use of dedicated acoustic panels, ensures low noise emissions, particularly with regard to the EN12102-1:2022 standard. The reduction of the sound power level under A7/W55 conditions reaches 7 dB(A).

Provided separately

- **SAS** - DHW sensor / Remote system sensor – in some system configurations (e.g. heat pump in parallel with the boiler on the same hydronic circuit and diverter valve for exclusion) it may be necessary to enable a system temperature sensor so that the unit-mounted controller can correctly manage operation.

The remote system sensor controls the heat pump temperature only during the compressor start-up phase; shutdown is managed by the sensor installed on the heat pump flow line.
- **SPS** - Solar panel probe for GI3 – probe required to measure the temperature of the solar panels when the unit is integrated with a solar thermal system.
- **AG** - Anti-vibration kit – designed to prevent transmission of vibrations to the structure; must be installed under the unit, in the dedicated mounting holes.
- **VRC** - Condensate drip tray – galvanized sheet metal container to be installed at the base of the unit for collecting condensate water.
- **FY** - Y-strainer – contains a stainless steel mesh screen (500 µm filtration) that collects solid materials present in the water. Filtration prevents blockage and/or damage to the devices installed downstream of the strainer. Alternatively, it is possible to install a dirt separator that ensures a filtration level not greater than 1 mm (in this case, it is no longer necessary to install the Y-strainer).
- **FD** - Dirt separator – allows the heavier impurities present in the hydraulic circuit to be stopped and retained, as they are captured by a synthetic filter mesh and collected in a settling chamber. A magnetic device located inside the body of the dirt separator also makes it possible to trap ferromagnetic particles.
- **VDIS3** - Diverter valve – 3-way motorized ball valve Kvs 20.8, 1" 1/4 F connections, complete with actuator.
- **ACT** - Technical storage tank (see dedicated section)
- **VSA** - Anti-freeze thermal discharge valve – a valve capable of opening at 0°C to prevent ice formation inside the pipes.
- **RP** - Coil protection grilles – wire mesh to prevent foreign objects from entering the coil and to protect the coil from accidental contact with objects or people (supplied as a separate accessory and to be installed by the installer).
- **e-LITE**** - Color touch-screen wired controller, which can be used as a remote keypad for the heat pump, as it replicates the functions of the on-board unit display. It is equipped with local temperature sensing and time scheduling.
- **Hi-TV415**** - Color touchscreen wired remote controller for centralized management of a chiller/heat pump cascade, for up to 7 units.
- **Connect Box**** - Wi-Fi communication gateway for the Maxa Connect App.
- **GI3**** - External system management module – enables management of the following functions: recirculation pump control, plant-side mixing valve control, solar thermal integration control.
- **ISK**** - USB/RS485 serial converter – interface device capable of reading and writing control registers via the RS485 standard and converting them to a USB port that can be connected to any supervision system.
- **LNC**** - LAN-Wi-Fi router – device that allows the unit to be connected to a local network via Ethernet cable or Wi-Fi coverage for remote monitoring.
- **OVPN**** - 3G LAN-Wi-Fi router with VPN tunnel – device that allows the unit to be connected remotely with an industrial router using the secure OPENVPN service.



e-PRO
Wi-Fi multifunction remote controller
STANDARD



e-LITE
Multifunction remote controller
ACCESSORY



Hi-TV415
Touch screen remote controller for cascade management (max 7 units)
ACCESSORY

			0121	0123	0125	0127
Cooling	Cooling capacity (1)	kW	17,4	18,9	19,8	22,3
	Power input (1)	kW	5,26	5,89	6,19	7,19
	EER (1)	W/W	3,31	3,21	3,20	3,10
	Cooling capacity (2)	kW	19,6	21,0	25,3	27,9
	Power input (2)	kW	4,02	4,38	5,32	6,43
	EER (2)	W/W	4,88	4,79	4,76	4,34
	SEER (5)	W/W	5,27	5,27	4,94	4,84
Heating	Water flow rate (1)	L/s	0,83	0,90	0,95	1,07
	Heating capacity (3)	kW	21,0	22,8	24,8	27,0
	Input power (3)	kW	4,31	4,78	5,37	6,21
	COP (3)	W/W	4,87	4,77	4,62	4,35
	Heating capacity (4)	kW	19,6	21,6	23,2	26,3
	Power input (4)	kW	6,13	6,79	7,66	8,74
	COP (4)	W/W	3,20	3,18	3,03	3,01
	Heating capacity (12)	kW	19,7	21,2	24,1	25,8
	Power input (12)	kW	7,38	7,97	9,56	10,3
	COP (12)	W/W	2,67	2,66	2,52	2,50
	Thermal power (13)	kW	17,5	18,6	19,5	21,1
	Power input (13)	kW	6,05	6,71	7,19	7,55
	COP (13)	W/W	2,89	2,77	2,71	2,79
	SCOP (6)	W/W	4,86	4,72	4,49	4,46
	Water flow rate (4)	L/s	0,59	0,65	0,69	0,79
	Energy efficiency - water 35°C / 55°C - low / medium temperature	Class	A+++ / A++	A+++ / A++	A+++ / A++	A+++ / A++
	Compressor	Type	-	Scroll DC Inverter		
Number		-	1	1	1	1
Refrigerant oil (type)		-	PZ46M	PZ46M	PZ46M	PZ46M
Refrigerant oil (quantity)		mL	900	900	900	900
Refrigerant circuits		-	1			
Refrigerant	Type	-	R290			
	Refrigerant quantity (7)	kg	1,7	1,7	2,1	2,1
	Refrigerant quantity in tons of CO ₂ equivalent (7)	Ton	0,000034	0,000034	0,000042	0,000042
	Operating pressure in chiller (high/low)	bar	30,3 / 1,7			
	Operating pressure in heat pump mode (high/low)	bar	30,3 / 0,7			
Ventilation	Type	-	EC			
	Number	-	1			
	Rated power (1)	kW	0,40	0,43	0,59	0,58
	Maximum absorbed power	kW	0,83	0,83	0,83	0,83
	Maximum absorbed current	A	1,2	1,2	1,2	1,2
	Nominal air flow rate	m ³ /h	12520	12810	13770	13780
Internal heat exchanger	Internal heat exchanger type	-	Plate / BPHE			
	No. of indoor heat exchangers	-	1	1	1	1
	Water content	L	1,71	1,71	2,07	2,07
Hydraulic circuit	Available head (1)	kPa	128	121	128	117
	Available head (4)	kPa	150	146	149	142
	Water content of hydronic circuit	L	3,6	3,6	4,0	4,0
	Maximum hydronic circuit pressure (safety valve setting)	bar	6	6	6	6
	Hydraulic connections	inch	1" 1/4 M	1" 1/4 M	1" 1/4 M	1" 1/4 M
	Minimum water volume (8)	L	175	175	220	225
	Rated pump power (1)	kW	0,350	0,350	0,350	0,350
	Maximum absorbed pump power	kW	0,350	0,350	0,350	0,350
	Maximum absorbed pump current	A	2,5	2,5	2,5	2,5
	Sound power level L _w (9) std / SSL	dB(A)	72 / 70	73 / 71	75 / 73	76 / 74
Sound data	Sound pressure L _{p1} (10) std / SSL	dB(A)	41 / 39	42 / 40	44 / 42	45 / 43
	Sound power L _w (11) std / SSL	dB(A)	64 / 57	64 / 57	65 / 58	65 / 58
	Power supply	-	400V/3P+N+T/50Hz			
Electrical data	Maximum absorbed power	kW	11	11	13	13
	Maximum absorbed current	A	19	19	21	21
	Maximum power input with antifreeze kit	kW	11	11	13	13
	Maximum current draw with antifreeze kit	A	19	19	22	22

Performance referred to the following conditions, in accordance with standard UNI EN 14511:2022:

- (1) Cooling: outdoor air temperature 35 °C; inlet/outlet water temperature 12/7 °C.
- (2) Cooling: outdoor air temperature 35 °C; inlet/outlet water temperature 23/18 °C.
- (3) Heating: outdoor air temperature 7 °C d.b. 6 °C w.b.; inlet/outlet water temperature 30/35 °C.
- (4) Heating: outdoor air temperature 7 °C d.b. 6 °C w.b.; water inlet/outlet temp. 47/55 °C.
- (5) Cooling: low temperature, variable output, constant flow rate.
- (6) Heating: average climate conditions; T_{biv} = -7 °C; low temperature, variable output, constant flow rate.
- (7) Indicative data subject to change. For the correct data, always refer to the technical nameplate on the unit.
- (8) Calculated for a 10 °C decrease in system water temperature with a defrost cycle lasting 6 minutes.
- (9) Sound power: mode (1); value determined on the basis of measurements carried out in

accordance with standard UNI EN ISO 9614-1.

- (10) Sound pressure: value calculated from the sound power level in condition (9) using standard UNI EN ISO 3744:2010.
- (11) Sound power: heating mode according to EN 12102:2022 Annex A; value determined on the basis of measurements carried out in accordance with UNI EN ISO 9614-1, in compliance with the requirements of Eurovent certification.
- (12) Heating: outdoor air temperature 7 °C d.b. 6 °C w.b.; water inlet/outlet temp. 55/65 °C.
- (13) Heating: outdoor air temperature -7 °C d.b. -8 °C w.b.; inlet/outlet water temp. 30/35 °C.

Note: the performance data shown are indicative and may be subject to change. Furthermore, the capacities declared at points (1), (2), (3) and (4) refer to the instantaneous output according to UNI EN 14511:2022. The data declared at points (5) and (6) are determined according to UNI EN 14825:2022.

Dimensional Drawings

i-290 0121 / 0127

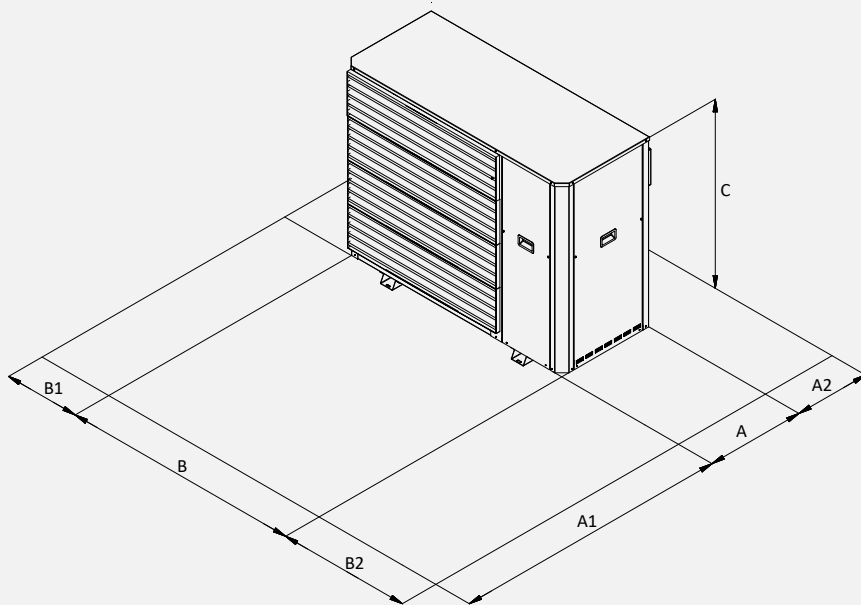
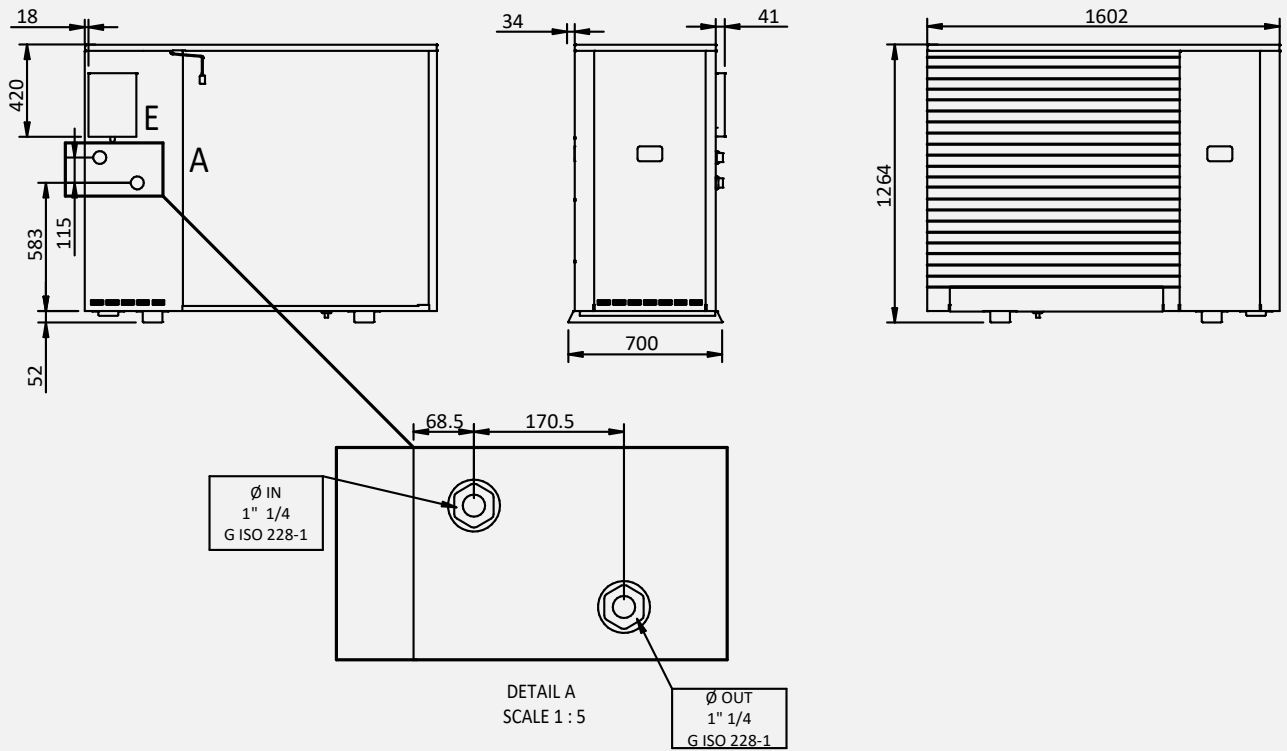

Clearances		A1	A2	B1	B2
0121	mm	1500	400	400	500
0123	mm	1500	400	400	500
0125	mm	1500	400	400	500
0127	mm	1500	400	400	500

		0121	0123	0125	0127
L	mm	1610	1610	1610	1610
D	mm	710	710	710	710
H	mm	1270	1270	1270	1270
Shipping weight	kg	276	276	285	285

Dimensions in mm

System Diagram - Standard Application

1	i-290 0123 heat pump	7	Expansion vessel	15	Y-strainer / Dirt separator filter (FD)	22	Mixed circuit pump (zone 2)
2	3-way DHW/system valve (VDIS3)	10	Water connection	19	Degasser	22 ^{bis}	Direct circuit pump (zone 1)
3	DHW electric heater	11	Local thermostat (zone 1)	20	Mixing valve	24	Technical water tank
4	DHW temperature sensor (SAS)	11 ^{bis}	Local thermostat (zone 2)	21	Mixed circuit water sensor	30	GI3 - External extension module
5	DHW Tank (Caddy)	13	e-PRO control				

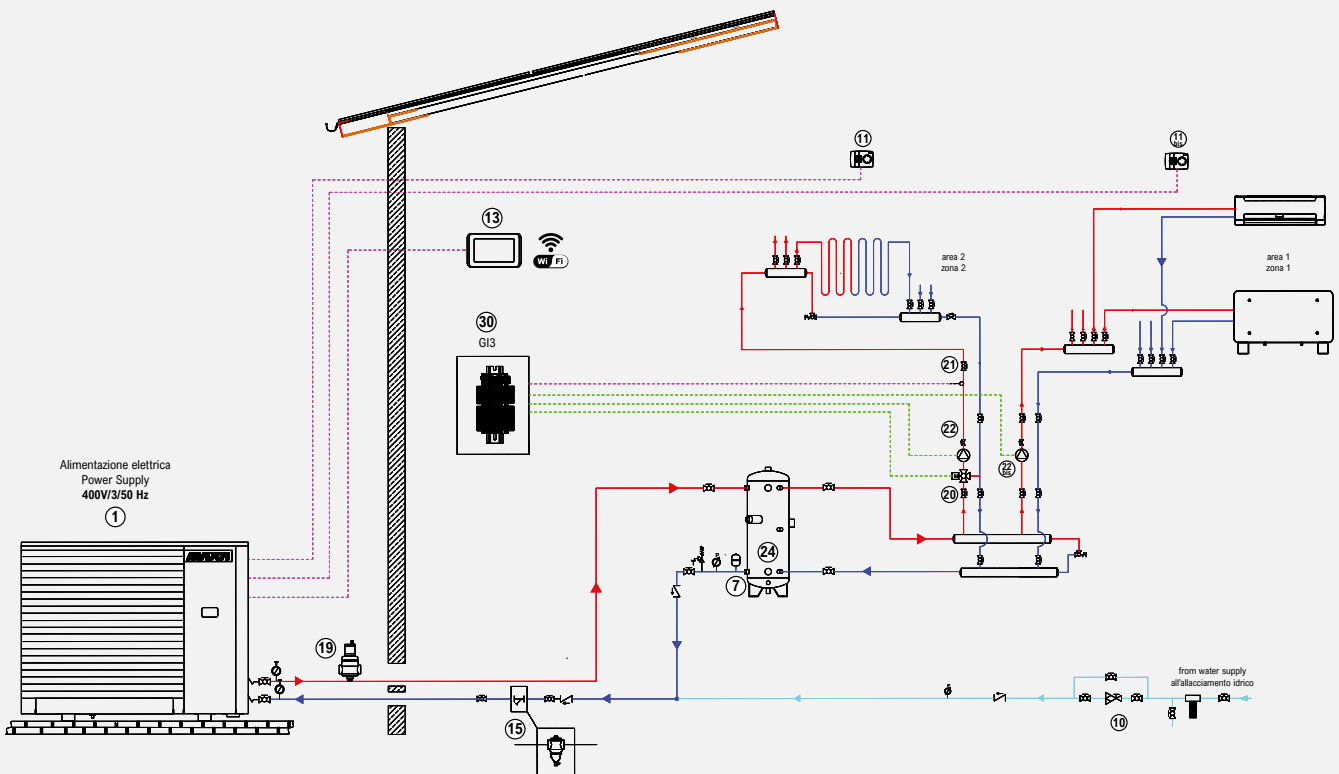
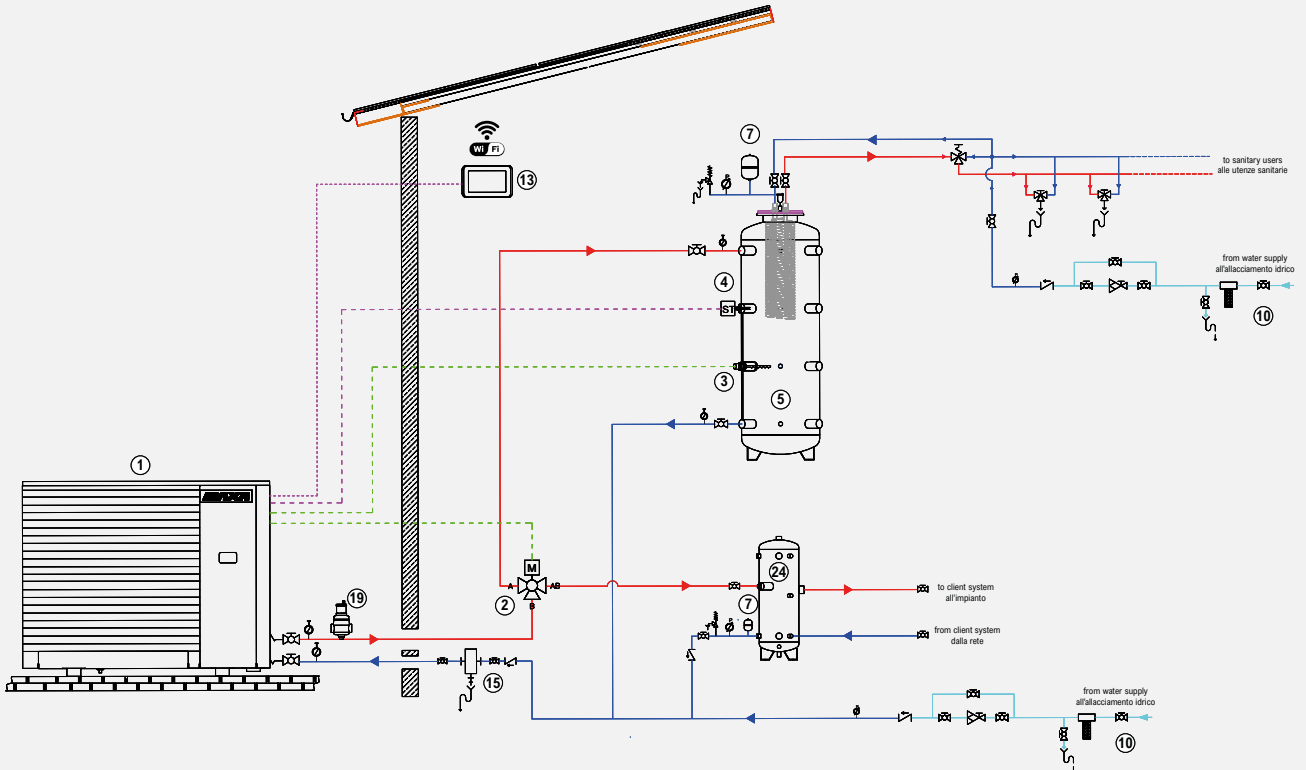

Purely indicative and non-binding diagram; for the construction of the system, it is necessary to refer to a design prepared by a qualified technician.

Price list

i-290			0121	0123	0125	0127
i-290	Reversible heat pump	£	18.592 *	18.870 *	20.172 *	20.543 *
e-PRO	Wired Remote control, Wi-Fi connected	£	included			
FACTORY-MOUNTED ACCESSORIES						
SSL	Super silencing	£	680	680	680	680
CM	Serial communication module for Modbus	£	813			
KA	Anti-freeze kit (heat exchanger + base)	£	399			
KA3	Adhesive base heater	£	247			
RP	Battery protection nets	£	496			
TR2	Cu/Al coil with anti-corrosion treatment	£	1.916		2.091	
TR2C4	Cu/Al coil and sheet metal with anti-corrosion treatment	£	4.532		4.707	
ACCESSORIES SUPPLIED SEPARATELY						
e-PRO*	Wired Remote control, Wi-Fi connected	code	010022520010			
		£	450			
e-LITE*	Multifunction touch screen wired control	code	0110490101			
		£	450			
Hi-TV415*	Centralized multifunction touch screen remote control	code	010312300001			
		£	640			
Connect Box **	Heat pump communication gateway and MAXA CONNECT	code	0110490103			
		£	309			
VSA	Anti-freeze thermal discharge valve	code	010112532490010			
		£	390			
GI3 **	Hardware expansion module	code	01821000001			
		£	860			
AG	Anti-vibration support	code	015908010050			
		£	233			
RP	Battery protection nets	code	01015253501			
		£	496			
FD	Dirt separator filter	code	0119100081			
		£	412			
FY	Y-strainer	code	0171214901			
		£	90			
SAS	DHW storage sensor - Remote sensor	code	0110321000001			
		£	47			
SPS	Solar panel sensor	code	CH-CC-EN-ST-0015			
		£	101			
VDIS3	Three-way diverting valve for domestic hot water production in a thermal storage tank	code	0110490102			
		£	436			

* Remote control connected and air vent included

* Accessories that cannot be used simultaneously

** Accessories not usable simultaneously

i-290 0240-0250

Monobloc inverter air-to-water reversible heat pump with R290

40 kW-50 kW

Sizes i-290 0240 and 0250 represent the latest evolution in MAXA full inverter heat pump technology. By using the environmentally friendly R290 refrigerant, it is possible to achieve the final evolutionary step that further simplifies the design of systems fully managed by the heat pump alone. In fact, thanks to a maximum temperature of 78°, direct application on systems requiring high supply temperatures is also very straightforward.

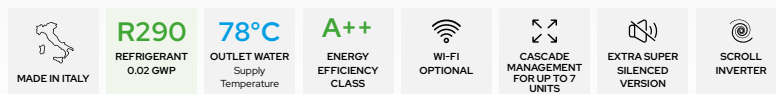

Construction Features

- Proprietary control system with microcontroller-based regulation, superheat control logic via electronic expansion valve.
- Compressors: DC inverter scroll.
- Fans: axial type with brushless DC motor.
- Source heat exchanger: copper tubes and aluminum fins with hydrophilic coating.
- User plate heat exchanger with AISI 304 stainless steel brazed plates, featuring low pressure drop on the water side.
- Refrigerant circuit made of copper tubing, including: 4-way reversing valve, electronic expansion valve, liquid separator, liquid receiver, high-pressure switch, pressure transducers, filter-drier, liquid sight glass with moisture indicator.
- Hydraulic circuit includes: plate heat exchanger, flow switch, safety valve (6 bar) and manual air vent valve.
- On request (optional), additional components such as a tank and circulation pump can be installed on board the unit.
- Electrical circuit equipped with a three-phase relay for overvoltage and undervoltage monitoring plus phase loss/sequence control. It indicates the presence of all three phases in the correct sequence and whether all three line-to-line voltages are within the set limits.
- Electrical circuit equipped with a digital input that can be activated by an external contact to reduce the sound power level by acting on the ventilation. This mode is particularly recommended for night-time operation.
- Presence of a leak detection sensor that ensures a high level of safety

Logics and Controls:

- All units can operate in three different modes: heating, cooling, and domestic hot water, with specific programs that maximize performance in all conditions, including optional control via climatic compensation curve.
- The i-290 series units are capable of managing mixing valves, diverting valves and secondary-side circulation pumps; they are also able to control the solar thermal system, any integration with external heat sources, and integration with external Home/Building Automation or Home Automation systems.
- The i-290 0240-0250 series can be fully managed via the onboard unit display.
- The range is compatible with the various MAXA remote control models, in particular: **e-Lite**, suitable for local control of a single heat pump; **Hi-TV415**, suitable for local control of a cascade of heat pumps; **e-Pro**, which enables both local and remote control of a single heat pump; or **CONNECT BOX**, which functions as a gateway between the heat pump and the local Wi-Fi network.

Operating Areas

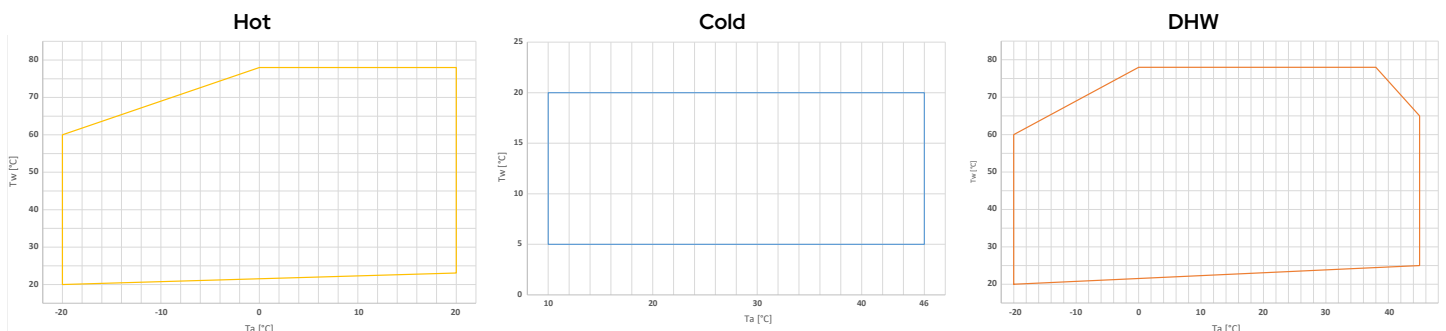

Tw: water temperature - Ta: outdoor air temperature

Accessories

Factory-installed

- **KA1** - Anti-freeze heater on: heat exchanger and pump - Electric heater installed on the front side of the plate heat exchanger, which is activated when the water temperature inside the exchanger drops below +4°C. If the selected hydronic kit includes the pump, this component will also be equipped with a heater that protects it from ice formation.
- **TR2** - Cu/Al coil with Silver Line surface treatment. Finned coil heat exchangers with copper tubes and aluminium fins, subjected to treatment with a special polyurethane-based paint for corrosion protection. The protection provides the coil with flexibility to withstand thermal contraction and expansion, UV resistance, and makes it dirt-repellent. The treatment ensures coil protection under virtually all environmental conditions: from marine to rural environments, from industrial to urban areas. For specific instructions on cleaning coils treated in this way, refer to the relevant chapter in the user-installer manual. The treatment withstands 6000 h according to ASTM B117.
- **TR2C4** - Anti-corrosion treatment on coil and sheet metal - includes a TR2-type treatment of the coil and, additionally, the hot-dip galvanized steel panels are painted so as to make them suitable for installation of the unit in C4H environments, in accordance with UNI EN 12944. The fastening hardware is suitable for installation in C4H environments.
- **RP** - Coil protection grid. Grids installed to protect finned coils. The grilles are used to protect the heat exchanger from accidental contact. They are especially recommended in locations where people or animals could damage, or be injured by, the finned heat exchanger. They can also be installed after the unit has been delivered.
- **CM** - BMS connectivity setup - ModBus protocol included - accessory that enables the connection of the unit to external controllers via serial cable with RS-485 electrical standard and ModBus RTU protocol.
- **IM** - Circuit breakers on compressors - Overcurrent switches applied to compressors, protecting components from faults caused by possible current spikes.
- **PS** - Fixed-speed AC circulation pump.
- **PSI** - AC circulation pump controlled via external inverter installed in the electrical panel.
- **PSEC** - Single EC pump equipped with integrated frequency converter (high head).
- **PS-SI** - Fixed-speed AC circulation pump with integrated 400-liter tank and 24-liter expansion vessel.
- **PSI-SI** - AC circulation pump controlled via external inverter installed in the electrical panel, with integrated 400-litre tank and 24-litre expansion vessel.
- **PSEC-SI** - Single EC pump equipped with integrated frequency converter (high head), with integrated 400-liter tank and 24-liter expansion vessel.
- **GL** - Packaging with wooden crate. Special packaging consisting of a wooden crate to protect the unit during transport. Optional; it is recommended for long-distance shipments (for example, container transport) or when the unit is stored in a warehouse where it may be subject to accidental damage. The boards that make up the structure comply with ISPM15 regulations.
- **SL** - Silenced Version. Involves the installation of sound-absorbing covers on the compressors, significantly reducing the unit's sound pressure level and ensuring quieter operation without altering performance.
- **SSL** - Super Silent Version. Maintains the features of the SL and incorporates an optimized diffuser that increases fan efficiency. This allows the fan speed to be reduced, lowering sound pressure and optimizing energy consumption, ensuring improved acoustic comfort.
- **EXSL** - Extra Silenced Version. Adds an additional sound-absorbing cover on the tandem compressors to the SL configuration, achieving a further noise reduction for applications that are particularly sensitive to acoustic impact.
- **EXSSL** - Extra Super Silenced version. Includes all SSL solutions and adds additional sound-absorbing cladding on the tandem compressors, for the maximum level of noise reduction available in the range.

Provided separately

- **SAS** - Domestic hot water probe / Remote system probe - in some system configurations (e.g. heat pump in parallel with the boiler on the same hydronic circuit and diverter valve for boiler exclusion), it may be necessary to enable a system temperature probe so that the unit controller can correctly manage the operation. The remote system probe controls the heat pump temperature only during the compressor start-up phase; shutdown is managed by the probe located on the heat pump flow line.
- **SPS** - Solar panel probe for GI3 - probe required to measure the temperature of the solar panels when the unit is integrated with a solar thermal system.
- **AG** - Anti-vibration kit - designed to prevent transmission of vibrations to the structure; must be installed under the unit, in the dedicated mounting holes.
- **FY** - Y-strainer - contains a stainless steel mesh screen (500 µm filtration) that collects solid materials present in the water. Filtration prevents blockage and/or damage to the devices installed downstream of the strainer. Alternatively, it is possible to install a dirt separator that ensures a filtration level not greater than 1 mm (in this case, it is no longer necessary to install the Y-strainer).
- **FD-DA** - Air Separator Kit - Use as air separator (installation in the system supply line): component that allows continuous capture and expulsion of air and any other gases dissolved in the water of the hydraulic circuit. The removal efficiency of this device is very high, allowing the elimination of non-condensable gases present in the circuits down to the level of microbubbles. Use as dirt separator (installation in the return pipe, before the inlet to the heat pump): allows blocking and retaining the heavier impurities present in the hydraulic circuit, which are captured by a synthetic filter mesh and collected in a settling chamber. A magnetic device located inside the body of the dirt separator also allows interception of ferromagnetic particles.
- **VDIS4** - Three-way diverting valve for DHW production. Valve that diverts the water flow produced by the heat pump between the system and a buffer tank for the production of domestic hot water. Three-way motorized ball valve, DN (1 1/2), Kvs 28, complete with actuator, insulation shell and spacer, ensuring correct operation even with glycolated water. The power cable from the actuator is 1 metre long.

** Accessories not usable simultaneously

Accessories

Provided separately

- **VSA** - Anti-freeze thermal discharge valve – a valve capable of opening at 0°C to prevent ice formation inside the pipes.
- **RP** - Coil protection grilles – wire mesh to prevent foreign objects from entering the coil and to protect the coil from accidental contact with objects or people (supplied as a separate accessory and to be installed by the installer).
- **RV** - Grooved connection joint. Carbon steel stub pipe featuring, on one side, a grooved connection complete with clamp for connection to the heat pump, and on the other side a G 1" 1/2 M threaded connection. The kit consists of 2 stub pipes and 2 grooved clamps.
- **GI3**** - External system management module - enables management of the following functions: recirculation pump control, plant-side mixing valve control, solar thermal integration control.
- **ISK**** - USB/RS485 serial converter – interface device capable of reading and writing control registers via the RS485 standard and converting them to a USB port that can be connected to any supervision system.
- **LNC**** - LAN-Wi-Fi router – device that allows the unit to be connected to a local network via Ethernet cable or Wi-Fi coverage for remote monitoring.
- **OVPN**** - 3G LAN-Wi-Fi router with VPN tunnel – device that allows the unit to be connected remotely with an industrial router using the secure OPENVPN service.
- **e-LITE**** - Color touch-screen wired controller, which can be used as a remote keypad for the heat pump, as it replicates the functions of the on-board unit display. It is equipped with local temperature sensing and time scheduling.
- **e-Pro**** - Color touch-screen Wi-Fi wired controller that allows both local and remote control via the MyMaxa app.
- **Hi-TV415**** - Color touchscreen wired remote controller for centralized management of a chiller/heat pump cascade, for up to 7 units.
- **Connect Box**** - Wi-Fi communication gateway for the Maxa Connect App.

** Accessories not usable simultaneously



e-PRO*
Wi-Fi multifunction remote controller
ACCESSORY



e-LITE
Multifunction remote controller
ACCESSORY



Hi-TV415
Touch screen remote controller for cascade management (max 7 units)
ACCESSORY

* Energy measurements not available

			0240	0250
Cooling	Cooling capacity (1)	kW	28,9	34,1
	Power input (1)	kW	9,20	11,0
	E.E.R. (1)	W/W	3,14	3,10
	Cooling capacity (2)	kW	34,5	37,0
	Power input (2)	kW	8,1	8,5
	E.E.R. (2)	W/W	4,26	4,34
	SEER (5)	W/W	4,86	4,80
	Water flow rate (1)	L/s	1,38	1,63
	Pressure drops on the hydronic circuit side (1)	kPa	24	26
Heating	Heating capacity (3)	kW	40,1	50,0
	Input power (3)	kW	9,8	11,9
	C.O.P. (3)	W/W	4,10	4,20
	Heating capacity (4)	kW	38,0	47,9
	Power input (4)	kW	13,1	16,5
	C.O.P. (4)	W/W	2,90	2,90
	Heating capacity (12)	kW	38,4	45,8
	Power input (12)	kW	16,0	18,8
	C.O.P. (12)	W/W	2,40	2,44
	Thermal power (13)	kW	34,6	38,1
	Power input (13)	kW	13,78	15,2
	C.O.P. (13)	W/W	2,51	2,52
	SCOP (6)	W/W	4,19	4,19
	Water flow rate (4)	L/s	1,14	1,43
	Pressure drops on the hydronic circuit side (4)	kPa	20	26
	Energy efficiency - water 35°C / 55°C	Class	A++ / A++	A++ / A++
Compressor	Type		Scroll DC Inverter	
	Number		2	2
	Refrigerant oil (type)		PZ46M	PZ46M
	Refrigerant oil (quantity)	mL	1800	1800
	Refrigerant circuits		1	1
Refrigerant	Type		R290	
	Refrigerant quantity (7)	kg	3,15	3,50
	Refrigerant quantity in tons of CO ₂ equivalent (7)	Ton	0,000063	0,000070
	Design pressure (high/low) chiller model	bar	30,3 / 1,7	
	Design pressure (high/low) heat pump model	bar	30,3 / 0,7	
Outdoor zone fans	Type		EC	
	Number		1	
	Rated power (1)	kW	0,62	0,69
	Maximum absorbed power	kW	1,95	1,95
	Maximum absorbed current	A	3,3	3,3
	Nominal air flow rate	m ³ /h	17080	18490
Internal heat exchanger	Internal heat exchanger type		Plate / BPHE	
	No. of indoor heat exchangers		1	1
	Water content	L	2,80	3,48
Hydraulic circuit	Water content of the hydronic circuit	L	4,5	5,2
	Maximum pressure of hydronic kit (safety valve setting)	bar	6	6
	Hydraulic connections	inch	1" 1/2 (DN 40)	1" 1/2 (DN 40)
	Minimum water volume (8)	L	365	415
Sound data	Sound power (9)	dB(A)	82	83
	Sound power level Lw SL configuration (9)	dB(A)	81	82
	Sound power level Lw EXSL configuration (9)	dB(A)	80	81
	Sound power level Lw SSL configuration (9)	dB(A)	79	80
	Sound power level Lw EXSSL configuration (9)	dB(A)	78	79
	Sound pressure level (10) at 1 m	dB(A)	64/63/62/62/61	64/64/63/62/62
	Sound power (11) STD-SL-EXSL	dB(A)	74	75
	Sound power level Lw configuration SSL-EXSSL (11)	dB(A)	73	74
Electrical data	Power supply		400V/3P+N+T/50Hz	
	Maximum absorbed power	kW	23	27
	Maximum absorbed current	A	37	44
	Maximum power input with antifreeze kit	kW	23	27
	Maximum current draw with antifreeze kit	A	38	45

- (1) Cooling: outdoor air temperature 35°C; inlet/outlet water temperature 12/7°C.
(2) Cooling: outdoor air temperature 35°C; inlet/outlet water temperature 23/18°C.
(3) Heating: outdoor air temperature 7°C d.b. 6°C w.b.; inlet/outlet water temperature 30/35°C.
(4) Heating: outdoor air temperature 7°C d.b. 6°C w.b.; inlet/outlet water temperature 47/55°C
(5) Cooling: low temperature, variable output, constant flow rate.
(6) Heating: average climatic conditions; T_{biv} = -7°C; low temperature, variable water outlet, fixed flow rate.
(7) Indicative data, subject to change. For the correct data, always refer to the technical nameplate on the unit.



to the total required; the designer must ensure this requirement is amount already present inside the unit, depending on the selected

- hydronic kit (please check this value in the technical data sheet).
(9) Sound power: mode (1); value determined on the basis of measurements carried out in accordance with standard UNI EN ISO 9614-1.
(10) Sound pressure: calculated from the sound power level using ISO 3744:2010, considering the units operating in free field conditions.
(11) Sound power: heating mode according to EN 12102:2022 Annex A; value determined on the basis of measurements carried out in accordance with UNI EN ISO 9614-1, in compliance with the requirements of Eurovent certification.
(12) Heating: outdoor air temperature 7 °C d.b. 6 °C w.b.; water inlet/outlet temp. 55/65 °C.
(13) Heating: outdoor air temperature -7 °C d.b. -8 °C w.b.; inlet/outlet water temp. 30/35 °C.

Dimensional Drawings

i-290 0240 / 0250

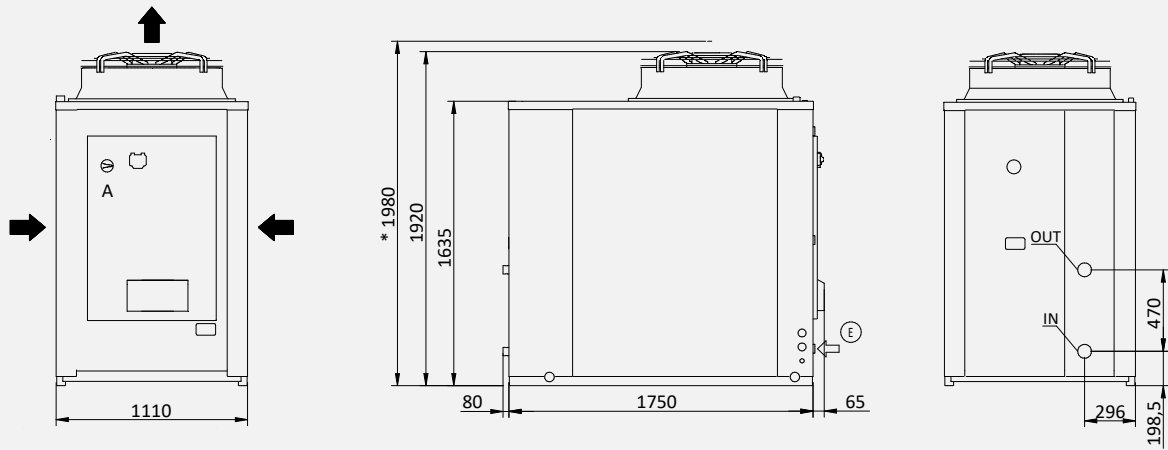

Version with tank kit

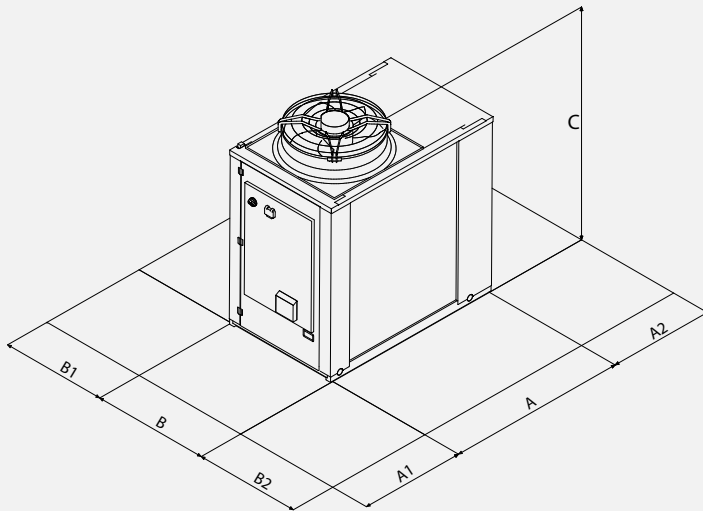
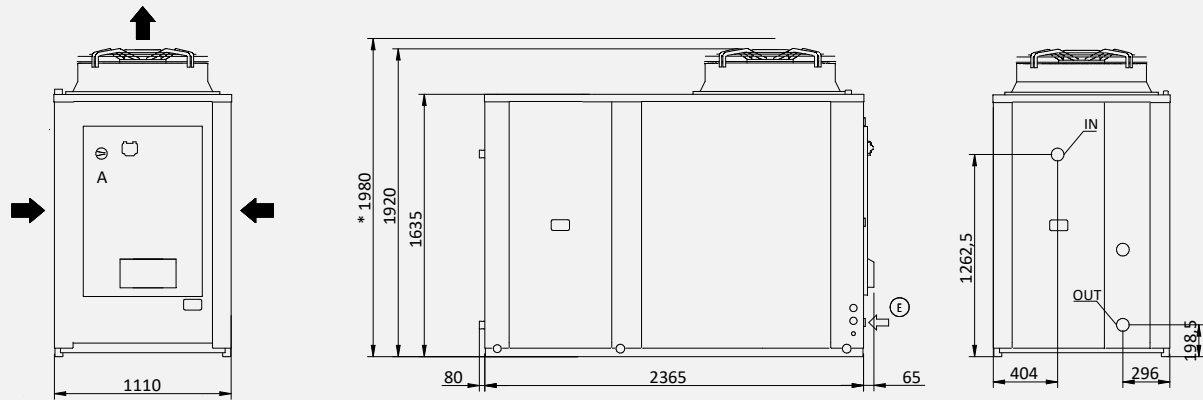

Clearances		A1	A2	B1	B2
0240	mm	1200	1000	1500	1500
0250	mm	1200	1000	1500	1500

		0240	0250
L	mm	1895	1895
L (with tank)	mm	2510	2510
D	mm	1110	1110
H	mm	1920	1920
H (SSL)	mm	1980	1980
Shipping weight	kg	510	525

IN/OUT: 1" 1/2 Grooved
E: Power supply input

Dimensions in mm

System Diagram - Standard Application

1	i-290 0240-0250 heat pump	5	DHW tank (Puffroller)	10	Water connection	15	Y-strainer
2	3-way DHW/system valve (VDIS4)	6	Fast DHW heater	12	Hi-TV415 Control	19	FD-DA
4	DHW temperature sensor (SAS)	7	Expansion vessel	13	e-PRO control	24	Technical water tank (Puffroller)

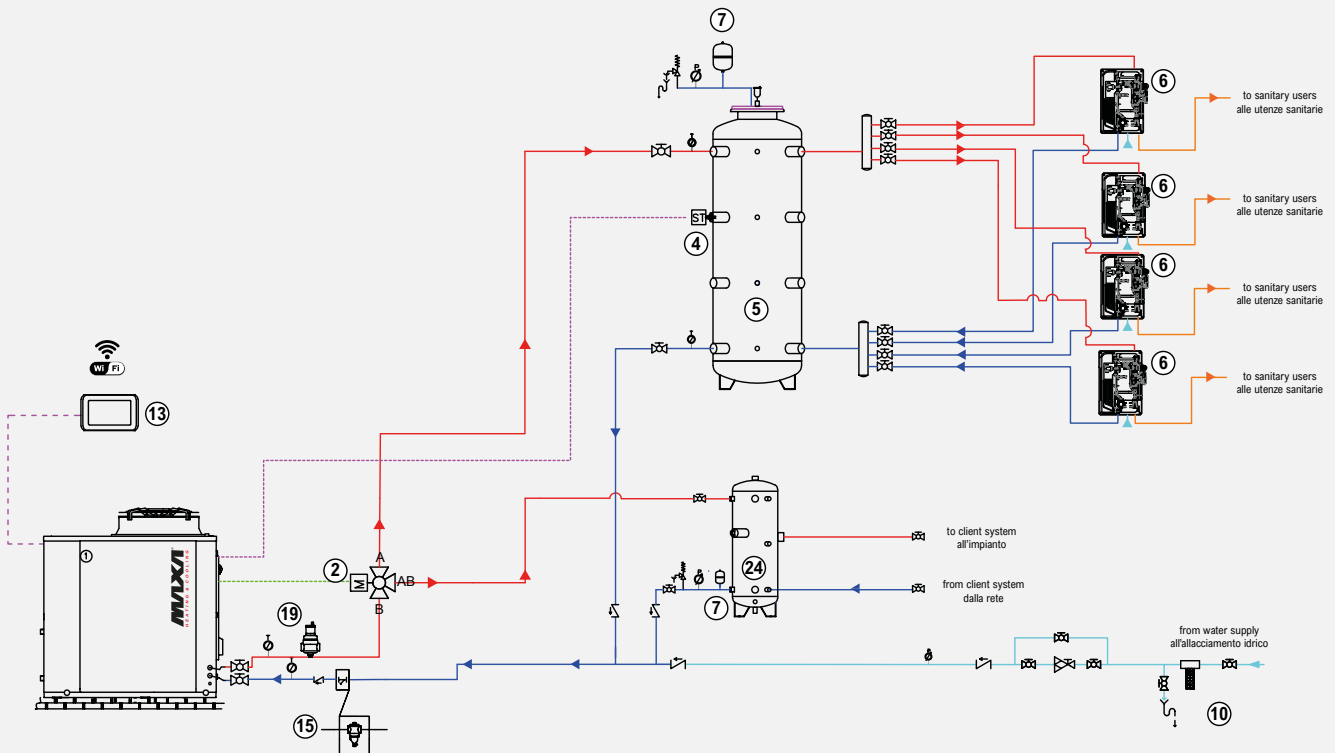
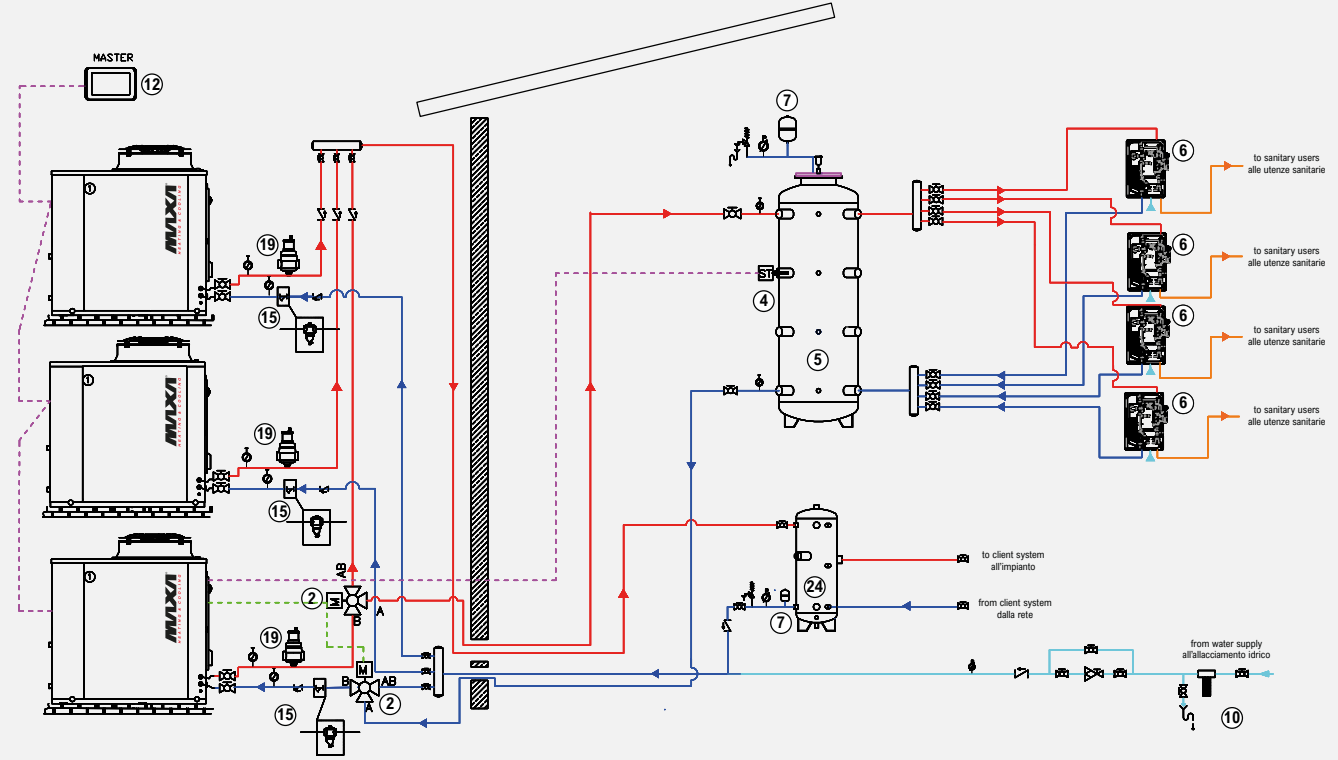

Purely indicative and non-binding diagram; for the construction of the system, it is necessary to refer to a design prepared by a qualified technician.

Price list

i-290			0240	0250
i-290	Reversible inverter heat pump	£	39.253	40.526
FACTORY-MOUNTED ACCESSORIES				
CM	Serial communication module for Modbus	£		853
GL	Crate packaging in wooden cage	£		422
	Crate packaging in wooden frame (with YES accessory)	£		584
IM	Magnetothermal circuit breakers	£		752
KA1	Adhesive resistance heat exchanger + pump resistance (if present)	£		402
PS	Single AC pump	£		1.978
PSI	Single variable-speed AC pump with inverter control	£		2.826
PSEC	Single EC pump	£		4.761
PS-SI	Single AC pump and buffer tank	£		5.763
PSI-SI	Single inverter-driven modulating AC pump and buffer tank	£		6.990
PSEC-SI	Single EC pump and buffer tank	£		8.392
RP	Battery protection nets	£		902
SL	Silencing	£		387
EX SL	Extra Silencing	£		1.737
SSL	Super soundproofing (includes SL)	£		1.530
EX SSL	Extra Super silencing (includes EX SL)	£		2.880
TR2	Cu/Al coil with anti-corrosion treatment	£	2.898	3.331
TR2C4	Cu/Al coil and sheet metal with anti-corrosion treatment	£	6.061	6.493
ACCESSORIES SUPPLIED SEPARATELY				
e-PRO*	Wired Remote control, Wi-Fi connected	code	010022520010	
		£	450	
e-LITE*	Multifunction touch screen wired control	code	0110490101	
		£	450	
Hi-TV415*	Centralized multifunction touch screen remote control	code	010312300001	
		£	640	
Connect Box **	Heat pump communication gateway and MAXA CONNECT	code	0110490103	
		£	309	
GI3 **	Hardware expansion module	code	01821000001	
		£	860	
FY	Y-strainer	code	017221NN01	
		£	143	
AG	Anti-vibration support	code	019221NN01	
		£	505	
RP	Battery protection nets	code	01025242201	
		£	902	
FD-DA	Defanging Filter / Deaerator Kit	code	0102724250010	
		£	1.851	
SAS	DHW storage probe - Remote probe	code	0110321000001	
		£	47	
SPS	Solar panel sensor	code	CH-CC-EN-ST-0015	
		£	101	
RV	Grooved Connection Joint	code	018221NN01	
		£	143	
VDIS4	Three-way diverting valve for domestic hot water production in a thermal storage tank	code	0110490094	
		£	620	
VSA	Anti-freeze drain valve for hydraulic circuit	code	010112532520010	
		£	540	

For accessories of the DAS monitoring system (ISK, LNC, OVPN), see chapter "Connection devices for Maxa DAS supervision system"

* Accessories that cannot be used simultaneously

** Accessories not usable simultaneously



01271 850 204 | energylabuk.com
sales@energylabuk.com | @the-energy-lab-solutions

Registered Address: Millennium House, Braham Crescent, Roundawell Business Park, Barnstaple, Devon, EX31-3TD United Kingdom | Company Number: 06586990

April 2025

MAXA[®]
HEATING & COOLING

www.maxa.it



All the information and scripts contained in this catalogue are exclusive property of ADVANTIX SPA. ADVANTIX SPA might have patterns, brands, copyrights or other rights of intellectual property in being or outstanding and covering certain subjects or belonging to some products shown in this catalogue. The possession of this catalogue does not imply the right to use these patterns, brands, copyright or other intellectual properties unless it is allowed by ADVANTIX SPA with a written agreement. ADVANTIX SPA does not assume responsibility for any errors or imprecision in the content of this catalog and reserves the right to make changes to its products any time without notice, according for technical or commercial market needs.